



Hydraulic Power Units

D, H and V-Pak Series

HY28-2661-CD/US





Quick Reference Data Chart

Pump Model No.	Tank Size Liters (Gallon)	Pump Flow LPM (GPM) @ 1725 RPM	Electrical Motors KW (HP)	Maximum* Bar (PSI)
D-Paks	18.9 (5)	2.2 - 10.2 (0.9 - 2.7)	0.37 (0.5) - 2.24 (3)	207 (3000)
H-Paks	37.9 (10), 75.7 (20), 113.6 (30), 151.4 (40)	2.2 - 26.1 (0.9- 6.3)	0.37 (0.5) - 14.9 (20)	207 (3000)
V-Paks	37.9 (10), 75.7 (20), 113.6 (30), 151.4 (40)	7.6 - 59.1 (2.0 - 15.6)	1.5 (2) - 14.9 (20)	207 (3000)

* See pump/motor combination, maximum pressure charts.

Warranty

The hydraulic components on these Parker Power Units are warranted for one year. This warranty may be extended to two years by using and properly maintaining Parker filters.

Installation Data:

See Installation/Maintenance Manual for specific recommendations pertaining to start-up, system cleanliness, fluids, temperature and other important factors relative to proper installation and use of these power units.

Standard Features

- Vertical Design
- Submerged Pump
- Spare Return Ports
- Precision Pump Mounting Adapters
- Suction Strainer
- Glycerine Filled Pressure Gage with Shut Off
- Oil Level Gage with Thermometer
- Relief Valve
- Breather and Fill Cap
- SAE Drain Plug
- Parker Connector Technology



Benefits

- Saves Floor Space
- Quieter Operation, Elimination of Potential Leak Point
- Longer Pump Life
- Protects Pump from Contamination
- Improved Diagnostics
- Helps to Maintain Trouble-Free Performance
- Protects Against System Shock
- Easy To Fill Reservoir
- Prevents Leaks

Schematic Symbol

(Hydraulic Schematic - Basic Unit)

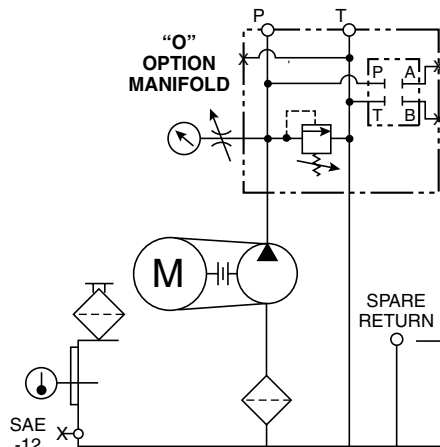

D & H-PAK BASIC UNIT
 NO OPTIONS OR ACCESSORIES
 "O" OPTION MANIFOLD

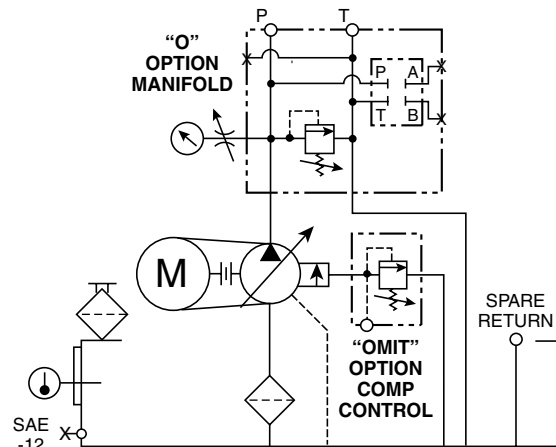

V-PAK BASIC UNIT
 NO OPTIONS OR ACCESSORIES
 "OMIT" OPTION PUMP COMPENSATOR
 "O" OPTION MANIFOLD

D-Paks

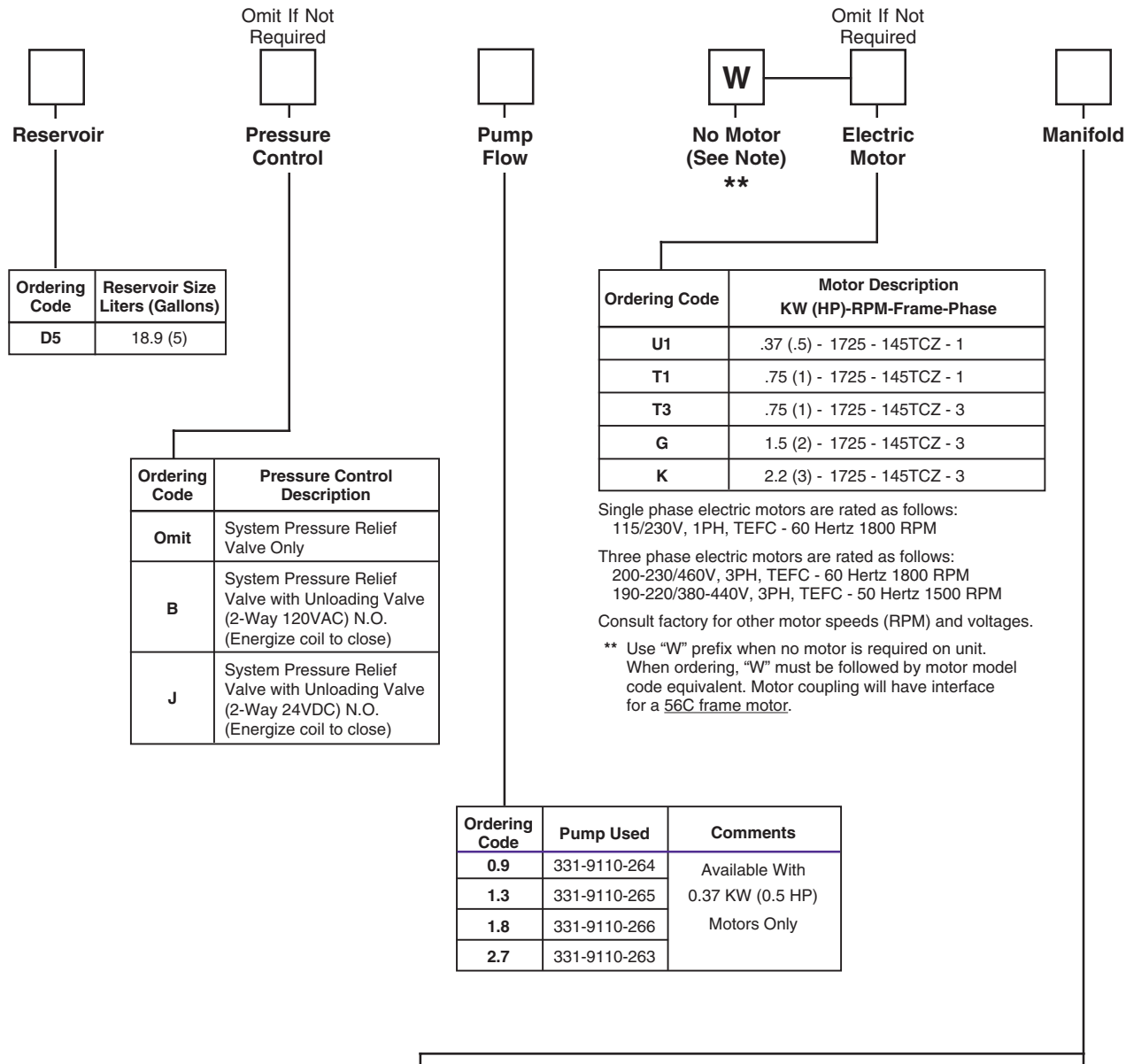

Ordering Code	Reservoir Size Liters (Gallons)
D5	18.9 (5)

Ordering Code	Pressure Control Description
Omit	System Pressure Relief Valve Only
B	System Pressure Relief Valve with Unloading Valve (2-Way 120VAC) N.O. (Energize coil to close)
J	System Pressure Relief Valve with Unloading Valve (2-Way 24VDC) N.O. (Energize coil to close)

Ordering Code	Motor Description KW (HP)-RPM-Frame-Phase
U1	.37 (.5) - 1725 - 145TCZ - 1
T1	.75 (1) - 1725 - 145TCZ - 1
T3	.75 (1) - 1725 - 145TCZ - 3
G	1.5 (2) - 1725 - 145TCZ - 3
K	2.2 (3) - 1725 - 145TCZ - 3

Single phase electric motors are rated as follows:
 115/230V, 1PH, TEFC - 60 Hertz 1800 RPM

Three phase electric motors are rated as follows:
 200-230/460V, 3PH, TEFC - 60 Hertz 1800 RPM
 190-220/380-440V, 3PH, TEFC - 50 Hertz 1500 RPM

Consult factory for other motor speeds (RPM) and voltages.

** Use "W" prefix when no motor is required on unit. When ordering, "W" must be followed by motor model code equivalent. Motor coupling will have interface for a 56C frame motor.

Ordering Code	Pump Used	Comments
0.9	331-9110-264	Available With 0.37 KW (0.5 HP) Motors Only
1.3	331-9110-265	
1.8	331-9110-266	
2.7	331-9110-263	

Ordering Code	Porting Block/Subplate or Manifold Type	Supply/Return Port or Actuator Port Size	Other
O	Pressure and Return Port Block with Safety Relief Valve	"P" & "T" Ports SAE-10 Str. Thr'd	Convertible to S3 Option
S3	D03 Single Station Subplate with Safety Relief Valve	"A" & "B" Ports SAE-8 Str. Thr'd	Spare "P" & "T" SAE-10 Ports
M33	D03 Multistation Parallel Circuit Manifold with Safety Relief Valve	"A" & "B" Ports SAE-8 Str. Thr'd	Spare "G" Port SAE-6

NOTE:
 Manifolds are mounted vertically.
 Bottom station is number 1.

D-Paks

Omit If Not Required †



Directional Control Valve

Omit If Not Required



***Manapak Control Valves**

Omit If Not Required



Options and Accessories

Consult Factory For Special Modifications

Ordering Code	Function	Valve Model Number	NFPA Mounting Pad	Nominal Flow LPM(GPM)	Circuit Symbol
1	Flow Control (Meter-Out)	FM2DDKN	D03	26.5 (7)	
3	Pilot Operator Check	CPOM2DDN	D03	26.5 (7)	

Manapak valves mounted in order of callout. First valve will be nearest DCV; last valve will be on manifold.

Ordering Code	Valve Model Number	NFPA Mounting Pad	Nominal Flow LPM(GPM)	Description	Circuit Symbol
B	D1VW001CN***	D03	26.5 (7)	Double (Spr. Ctr)	
C	D1VW004CN***	D03	26.5 (7)	Double (Spr. Ctr)	
T	D1VW008CN***	D03	26.5 (7)	Double (Spr. Ctr)	

† Units less valves will be supplied with station cover plates installed.

Ordering Code	Function	Model Number	Technical Data
B1*	Exchanger	RM-08-2-2	Air/Oil: 52KW (.7HP) Rej. @ 11.4 LPM(3 GPM)
H	Pressure Filter	15P110QXRS	Microglass II Element Vis. Ind. - 3.4 Bar (50 PSI) Bypass (.14 Bar (2 PSI)) Diff. @ 11.4 LPM (3 GPM))
K	Check Valve Pump Outlet	DT370MOMF05	.34 Bar (5 PSI) Cracking Pressure (.48 Bar (7 PSI)) Diff. @ 11.4 LPM (3 GPM))
L	Bypass Check (On Heat Exch)	C1020S65	4.5 Bar (65 PSI) Cracking Pressure
O	Return Filter	12AT10C (45 LPM (12 GPM))	Cellulose Element (Ind. Gage - 1.03 Bar (15 PSI)) Bypass Max. Oil Flow)
R1	Combination Float/Temp. Switch N.O. Float Up	876782-01	Fixed Temp at 65°C (149°F) Close @ Low Level and/or 65°C (149°F) (N.O.)
R2	Combination Float/Temp. Switch Float Up	876782-02	Fixed Temp at 65.6°C (150°F) Open @ Low Level and/or 65.6°C (150°F) (N.C.)

*Heat rejection based on flow given with a 40°F differential between transfer medium.

H-Paks

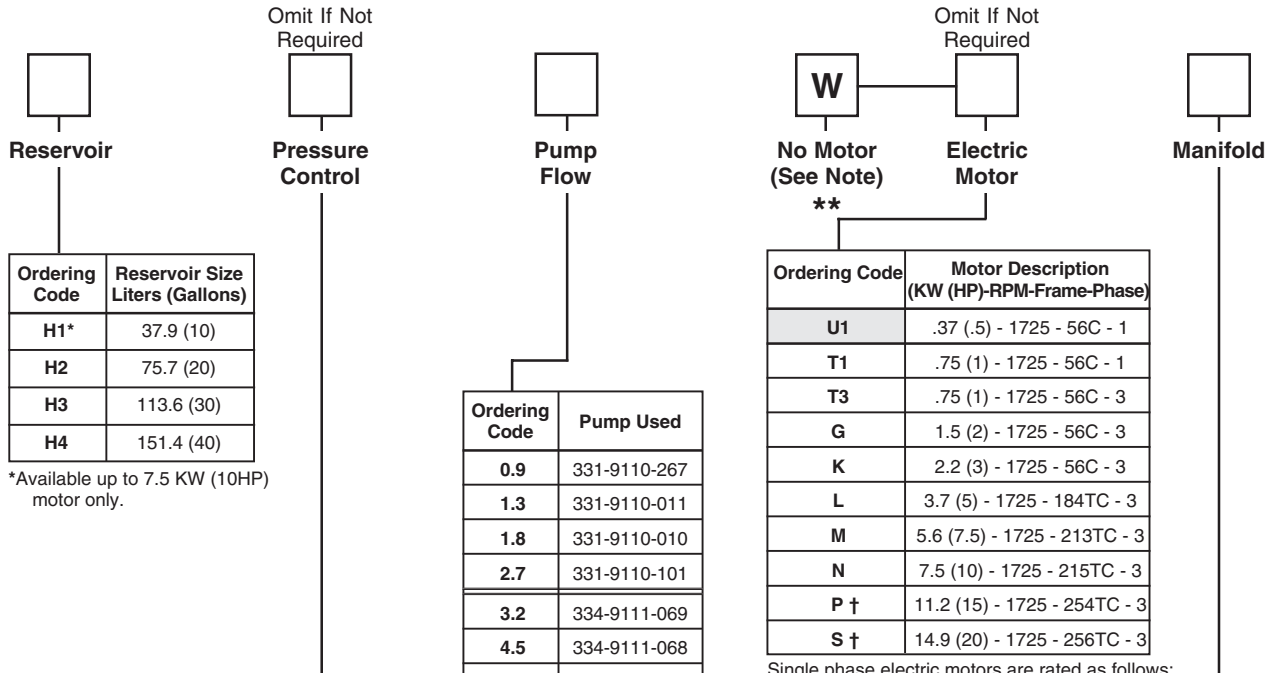

Ordering Code	Reservoir Size Liters (Gallons)
H1*	37.9 (10)
H2	75.7 (20)
H3	113.6 (30)
H4	151.4 (40)

*Available up to 7.5 KW (10HP) motor only.

Ordering Code	Pump Used
0.9	331-9110-267
1.3	331-9110-011
1.8	331-9110-010
2.7	331-9110-101
3.2	334-9111-069
4.5	334-9111-068
5.1	334-9111-067
6.3	334-9111-048

Ordering Code	Motor Description (KW (HP)-RPM-Frame-Phase)
U1	.37 (.5) - 1725 - 56C - 1
T1	.75 (1) - 1725 - 56C - 1
T3	.75 (1) - 1725 - 56C - 3
G	1.5 (2) - 1725 - 56C - 3
K	2.2 (3) - 1725 - 56C - 3
L	3.7 (5) - 1725 - 184TC - 3
M	5.6 (7.5) - 1725 - 213TC - 3
N	7.5 (10) - 1725 - 215TC - 3
P †	11.2 (15) - 1725 - 254TC - 3
S †	14.9 (20) - 1725 - 256TC - 3

Single phase electric motors are rated as follows:
 115/230V, 1PH, TEFC-60 Hertz 1800 RPM.

Three phase electric motors are rated as follows:
 208-230/460V, 3PH, TEFC-60 Hertz 1800 RPM.
 Consult factory for other motor speeds (RPM) and voltages.

**Use "W" prefix when no motor is required on unit. When ordering, "W" must be followed by motor model code equivalent to frame size of motor to be used.

†Available with H2, H3, H4 Tanks Only.

☐ Shaded option U1 leadtime is 2 weeks.

Ordering Code	Pressure Control Description
Omit	System Pressure Relief Valve Only
B	System Pressure Relief Valve with Unloading Valve (2-Way 120VAC) N.O. (Energize coil to close)
J	System Pressure Relief Valve with Unloading Valve (2-Way 24 VDC) N.O. (Energize coil to close)

Note: Two and three pressure control options with unloading valve available, consult factory.

Ordering Code	Porting Block/Subplate or Manifold Type	Supply/Return Port Actuator Port Size	Other
O	Pressure and Return Port Block with Safety Relief Valve	"P" & "T" Ports SAE-12 Str. Thr'd	Convertible to S3, S5, S6 Option
S3	D03 Single Station Subplate with Safety Relief Valve	"A" & "B" Ports SAE-8 Str. Thr'd	Spare "P" & "T" SAE-10 Ports
S5	D05 Single Station Subplate with Safety Relief Valve	"A" & "B" Ports SAE-10 Str. Thr'd	Spare "P" & "T" SAE-12 Ports
M33 M35	D03 Multistation Parallel Circuit Manifold with Safety Relief Valve	"A" & "B" Ports SAE-8 Str. Thr'd	Spare "G" Port SAE-6
M53 M55	D05 Multistation Parallel Circuit Manifold with Safety Relief Valve	"A" & "B" Ports SAE-8 Str. Thr'd	Spare "G" Port SAE-6

NOTE:
 Manifolds are mounted vertically.
 Bottom station is number 1.

H-Paks

Omit If Not Required †



Directional Control Valve

Omit If Not Required



***Manapak Control Valves**

Omit If Not Required

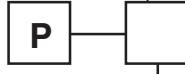

Options and Accessories

Not Required When Ordering



Consult Factory For Special Modifications

Design Series

Ordering Code	Function	Valve Model Number	NFPA Mounting Pad	Nominal Flow LPM(GPM)	Circuit Symbol
1	Flow Control	FM2DDKN	D03	26.5 (7)	
2	Flow Control	FM3DDKN	D05	45.4 (12)	
3	Pilot Operator Check	CPOM2DDN	D03	26.5 (7)	
4	Pilot Operator Check	CPOM3DDN	D05	45.4 (12)	

*Manapak valves mounted in order of callout. First valve will be nearest DCV; last valve will be on manifold.

Ordering Code	Valve Model Number	NFPA Mounting Pad	Nominal Flow LPM(GPM)	Description	Circuit Symbol
B	D1VW001CN***	D03	26.5 (7)	Double (Spr. Ctr)	
C	D1VW004CN***	D03	26.5 (7)	Double (Spr. Ctr)	
F	D3W1CN**	D05	75.7 (20)	Double (Spr. Ctr)	
G	D3W4CN**	D05	56.8 (15)	Double (Spr. Ctr)	
T	D1VW008CN***	D03	26.5 (7)	Double (Spr. Ctr)	
W	D3W8CN**	D05	56.8 (15)	Double (Spr. Ctr)	

Ordering Code	Function	Model Number	Technical Data
B1*	Return Heat Exchanger	RM-08-1-2	Air/Oil: .52 KW (.7 HP) Rejection @ 26.5 LPM (7 GPM) (.37 - 3.7 KW (.5 - 5 HP) Motors Only)
B2*	Return Heat Exchanger	RM-190-1-2	Air/Oil: 1.1 KW (1.5HP) Rejection @ 26.5 LPM (7 GPM) (5.6 - 11.2 KW (7.5 - 15 HP) Motors Only)
H	Pressure Filter	15P110QXRS	Microglass II Element Vis. Ind. -3.49 Bar (50 PSI) Bypass (.27 Bar (4 PSI) Diff. @ 26.5 LPM (7 GPM))
K	Check Valve Pump Outlet	"DT" & "C" Series	.34 Bar (5 PSI) Cracking Pressure (1.72 Bar (25 PSI) Diff. @ 56.8 LPM (15 GPM))
L	Bypass Check (On Heat Exch.)	C1220S65	4.5 Bar (65 PSI) Cracking Pressure
N	Return Filter	40CN110Q	Microglass II Element Visual 1.72 Bar (25 PSI) Indicator (.2 Bar (3 PSI) Diff. @ 26.5 LPM (7 GPM))
O	Return Filter	12AT10C (45.2 LPM (12 GPM) Max. Oil Flow)	Cellulose Element Ind. Gage - 1.03 Bar (15 PSI) Bypass
R1	Combination Float/Temp. SW N.O. Float Up	876782-01	Fixed Temp at 65°C (149°F) Close @ Low Level And/Or 65°C (149°F) (N.O.)
R2	Combination Float/Temp. SW N.O. Float Up	876782-02	Fixed Temp at 65.6°C (150°F) Open @ Low Level And/Or 65.6°C (150°F) (N.C.)

*Heat rejection based on flow given with a 4.4°C (40°F) differential between transfer medium.

† Units less valves will be supplied with station cover plates installed.

Note: Refer to options and accessories for voltage and connection choices.

V-Paks – 2 thru 7 GPM

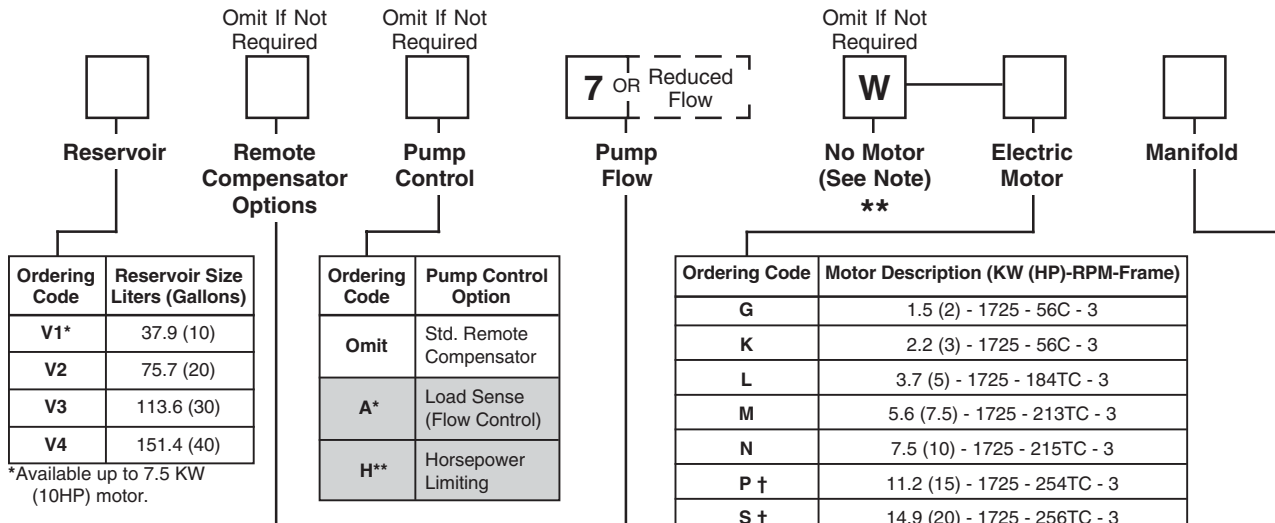

Ordering Code	Reservoir Size Liters (Gallons)
V1*	37.9 (10)
V2	75.7 (20)
V3	113.6 (30)
V4	151.4 (40)

*Available up to 7.5 KW (10HP) motor.

Ordering Code	Pump Control Option
Omit	Std. Remote Compensator
A*	Load Sense (Flow Control)
H**	Horsepower Limiting

NOTE: For shaded options A & H, lead time is four weeks.

* Unless otherwise specified, a SAE-6 sense port line will be supplied in topplate.

When shuttle check option (9 or 0) is specified on D03 or D05 manifold, sense line will be plumbed to shuttle check.

** Unless otherwise specified, horsepower setting will be at max. flow & pressure obtainable with motor selected. Reference Pump HP curves.

Ordering Code	Motor Description (KW (HP)-RPM-Frame)
G	1.5 (2) - 1725 - 56C - 3
K	2.2 (3) - 1725 - 56C - 3
L	3.7 (5) - 1725 - 184TC - 3
M	5.6 (7.5) - 1725 - 213TC - 3
N	7.5 (10) - 1725 - 215TC - 3
P †	11.2 (15) - 1725 - 254TC - 3
S †	14.9 (20) - 1725 - 256TC - 3

Electric motors are 208-230/460V, 60Hz, 3PH 1800 RPM. TEFC consult factory for other motor speeds (RPM) and voltages.

** Use "W" prefix when no motor is required on unit. When ordering, "W" must be followed by motor model code equivalent to frame size of motor to be used.

Ordering Code	Compensator Description
Omit	Single Pressure Remote Compensator
B	Single Pressure Remote Compensator With Low Pressure Standby
BJ	Single Pressure Remote Compensator With Low Pressure Standby, 24VDC
C	Bi-Pressure Remote Compensator
CJ	Bi-Pressure Remote Compensator, 24 VDC
D	Bi-Pressure Remote Compensator With Low Pressure Standby
DJ	Bi-Pressure Remote Compensator With Low Pressure Standby, 24VDC
F	Provision For Customer Supplied Remote Control Relief Valve

Ordering Code	Pump Flow Rate @ 1800 LPM (RPM)	Pump Used and Description
7	29.5 (7.8)	PVP16 - Std. Remote Compensator
*	Specify in GPM	Destroyed Max. Volume 7.57 LPM (2 GPM) Min.

* Unless otherwise specified, units are shipped at max. flow rate (29.5 LPM (7.8 GPM)) at 1800 RPM. When reduced flow setting is required, specify pump setting in .5 GPM increments. Example: 5, 5.5, 6, 6.5 with a 2 GPM minimum flow.

If horsepower limiting pump (H) control is required to be destroyed, utilize the special ordering code X.

Example: V*5**-- = Std. Pump Destroyed to 5 GPM

V*A4.5**-- = Load Sense Pump Destroyed to 4.5 GPM

Ordering Code	Pump Control/Mounting	Supply/Return Port Actuator Port Size	Other
O	Pressure and Return Port Block with Safety Relief Valve	"P" & "T" Port SAE-12 Str. Thr'd	Convertible to S3, S5, S6 Option
S3	D03 Single Station Subplate with Safety Relief Valve	"A" & "B" Ports SAE-8 Str. Thr'd	Spare "P" & "T" SAE-10 Ports
S5	D05 Single Station Subplate with Safety Relief Valve	"A" & "B" Ports SAE-10 Str. Thr'd	Spare "P" & "T" SAE-12 Ports
M33 M35	D03 Multistation Parallel Circuit Manifold with Safety Relief Valve	"A" & "B" Ports SAE-8 Str. Thr'd	Spare "G" Port SAE-6
M53 M55	D05 Multistation Parallel Circuit Manifold with Safety Relief Valve	"A" & "B" Ports SAE-8 Str. Thr'd	Spare "G" Port SAE-6

* When ordering Multi-Station Manifolds, the number of stations must be specified. If more than 5 stations required, consult factory. If valves are to be mounted, specify the valves and sequence. If the model code exceeds 25 digits, utilize the special ordering code X.

Example: V2 7 N M33X
 X= 3 Station Manifold
 Station #1: A
 Station #2: B
 Station #3: C24

NOTE:
 Manifolds are mounted vertically.
 Bottom station is number 1.

V-Paks – 2 thru 7 GPM

Omit If Not
 Required †



**Directional
 Control Valve**

Omit If Not
 Required



****Manapak
 Control Valves**

Omit If Not
 Required



Accessories

**Consult Factory
 For Special Modifications**

Not Required
 When Ordering



Design Series

Ordering Code	Function	Valve Model Number	NFPA Mounting Pad	Nominal Flow LPM(GPM)	Circuit Symbol
1	Flow Control Meter Out	FM2DDKN	D03	26.5 (7)	
2	Flow Control Meter Out	FM3DDKN	D05	45.4 (12)	
3	Pilot Operator Check	CPOM2DDN	D03	26.5 (7)	
4	Pilot Operator Check	CPOM3DDN	D05	45.4 (12)	

* Manapak valves mounted in order of callout. First valve will be nearest DCV; last valve will be on manifold.

Ordering Code	Valve Model Number	NFPA Mounting Pad	Nominal Flow LPM(GPM)	Description	Circuit Symbol
B	D1VW001CN***	D03	26.5 (7)	Double (Spr. Ctr)	
C	D1VW004CN***	D03	26.5 (7)	Double (Spr. Ctr)	
F	D3W1CN**	D05	75.7 (20)	Double (Spr. Ctr)	
G	D3W4CN**	D05	56.8 (15)	Double (Spr. Ctr)	

† Units less valves will be supplied with station cover plates installed.

Note: Refer to options and accessories for voltage and connection choices.

Ordering Code	Function	Model Number	Technical Data
A*	Pump Case Heat Exchanger	RM-08-4-2	Air/Oil: .52 KW (.7HP) Rejection @ 1.9 LPM (.5 GPM) (1.5-11.2KW (2-15HP) Motors)
B1*	Return Heat Exchanger	RM-08-1-2	Air/Oil: .52 KW (.7HP) Rejection @ 26.5 LPM (7 GPM) (1.5-3.7KW (2-5HP) Motors Only)
B2*	Return Heat Exchanger	RM-190-1-2	Air/Oil: 1.1KW (1.5HP) Rejection @ 26.5 LPM (7 GPM) (5.6-11.2KW (7.5-15HP) Motors Only)
H	Pressure Filter	15P110BXRS	Microglass II Element Vis. Ind. - 3.4 Bar (50 PSI) Bypass (.28 Bar (4 PSI) Diff. @ 26.5 LPM (7 GPM))
K	Check Valve Pump Outlet	DT750MOMF05	.34 Bar (5 PSI) Cracking Pressure (.55 Bar (8 PSI) Diff. @ 26.5 LPM (7 GPM))
L	Bypass Check (On Heat Exch.)	C1220S65	4.48 Bar (65 PSI) Cracking Pressure
N	Return Filter	40CN110B	Microglass II Element Visual 1.72 Bar (25 PSI) Indicator (.21 Bar (3 PSI) Diff. @ 26.5 LPM (7 GPM))
O	Return Filter	12AT10C (45.2 LPM (12 GPM) Max. Oil Flow)	Cellulose Element Ind. Gage - 1.03 Bar (15 PSI) Bypass
R1	Combination Float/Temp. SW N.O. Float Up	876782-01	Fixed Temp at 65°C (149°F) Close @ Low Level And/Or 65°C (149°F) (N.O.)
R2	Combination Float/Temp. SW N.O. Float Up	876782-02	Fixed Temp at 65.6°C (150°F) Open @ Low Level And/Or 65.6°C (150°F) (N.C.)

*Heat rejection based on flow given with a 4.4°C (40°F) differential between transfer medium.

V-Paks – 8 thru 15 GPM

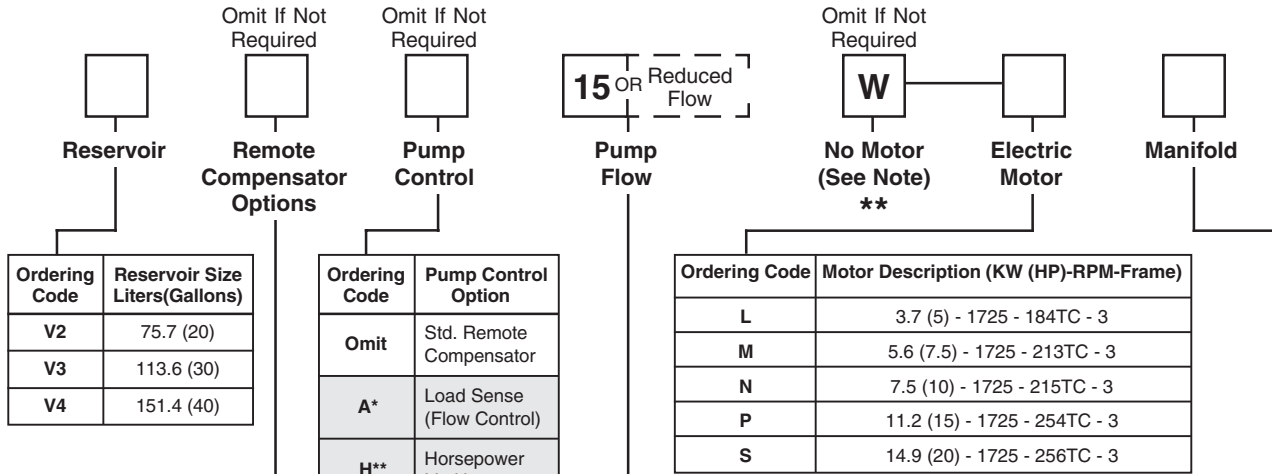

Ordering Code	Reservoir Size Liters(Gallons)
V2	75.7 (20)
V3	113.6 (30)
V4	151.4 (40)

Ordering Code	Pump Control Option
Omit	Std. Remote Compensator
A*	Load Sense (Flow Control)
H**	Horsepower Limiting

Ordering Code	Motor Description (KW (HP)-RPM-Frame)
L	3.7 (5) - 1725 - 184TC - 3
M	5.6 (7.5) - 1725 - 213TC - 3
N	7.5 (10) - 1725 - 215TC - 3
P	11.2 (15) - 1725 - 254TC - 3
S	14.9 (20) - 1725 - 256TC - 3

Electric motors are 208-230/460V, 60Hz, 3PH 1800 RPM. TEFC consult factory for other motor speeds (RPM) and voltages.

** Use "W" prefix when no motor is required on unit. When ordering, "W" must be followed by motor model code equivalent to frame size of motor to be used.

NOTE: For shaded options A & H, lead time is four weeks.

* Unless otherwise specified, a SAE-6 sense port line will be supplied in topplate.

When shuttle check option (9 or 0) is specified on D03 or D05 manifold, sense line will be plumbed to shuttle check.

** Unless otherwise specified, horsepower setting will be at max. flow & pressure obtainable with motor selected. Reference Pump HP curves.

Ordering Code	Compensator Description
Omit	Single Pressure Remote Compensator
B	Single Pressure Remote Compensator With Low Pressure Standby
BJ	Single Pressure Remote Compensator With Low Pressure Standby, 24VDC
C	Bi-Pressure Remote Compensator
CJ	Bi-Pressure Remote Compensator, 24 VDC
D	Bi-Pressure Remote Compensator With Low Pressure Standby
DJ	Bi-Pressure Remote Compensator With Low Pressure Standby, 24VDC
F	Provision For Customer Supplied Remote Control Relief Valve

Ordering Code	Pump Flow Rate @ 1800 RPM LPM (GPM)	Pump Used and Description
15	59 (15.6)	PVP33 - Std. Remote Compensator
*	Specify in GPM	Destroyed Max. Volume (8 GPM Min.)

* Unless otherwise specified, units are shipped at max. flow rate (59 LPM (15.6 GPM)) at 1800 RPM. When reduced flow setting is required, specify pump setting in .5 GPM increments. Example: 11, 11.5, 12, 12.5 with a 8 GPM minimum flow.

If horsepower limiting pump (H) control is required to be destroyed, utilize the special ordering code X.

Example: V*12**-- = Std. Pump Destroyed to 12 GPM

V*A11.5**-- = Load Sense Pump Destroyed to 11.5 GPM

Ordering Code	Porting Block/Subplate or Manifold Type	Supply/Return Port or Actuator Port Size	Other
O	Pressure and Return Port Block with Safety Relief Valve	"P" & "T" Ports SAE-12 Str. Thr'd	Convertible to S3, S5, S6 Option
S3	D03 Single Station Subplate with Safety Relief Valve	"A" & "B" Ports SAE-8 Str. Thr'd	Spare "P" & "T" SAE-10 Ports
S5	D05 Single Station Subplate with Safety Relief Valve	"A" & "B" Ports SAE-10 Str. Thr'd	Spare "P" & "T" SAE-12 Ports
M33 M35	D03 Multistation Parallel Circuit Manifold with Safety Relief Valve	"A" & "B" Ports SAE-8 Str. Thr'd	Spare "G" Port SAE-6
M53 M55	D05 Multistation Parallel Circuit Manifold with Safety Relief Valve	"A" & "B" Ports SAE-8 Str. Thr'd	Spare "G" Port SAE-6

NOTE:
 Manifolds are mounted vertically.
 Bottom station is number 1.

V-Paks – 8 thru 15 GPM

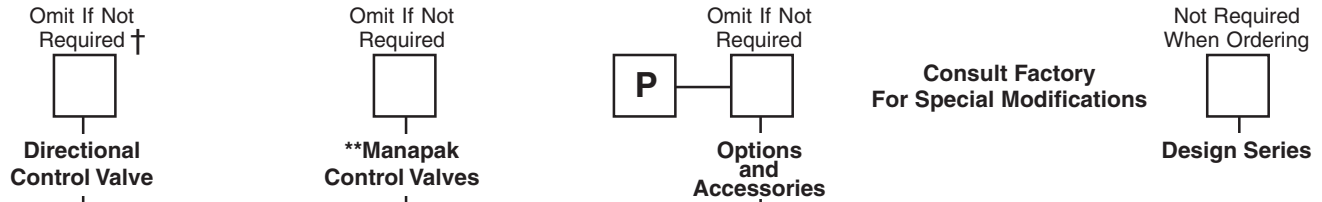

Ordering Code	Function	Valve Model Number	NFPA Mounting Pad	Nominal Flow LPM(GPM)	Circuit Symbol
1	Flow Control (Meter-Out)	FM2DDKN	D03	26.5 (7)	
2	Flow Control (Meter-Out)	FM3DDKN	D05	45.4 (12)	
3	Pilot Operator Check	CPOM2DDN	D03	26.5 (7)	
4	Pilot Operator Check	CPOM3DDN	D05	45.4 (12)	

** Manapak valves mounted in order of callout. First valve will be nearest DCV; last valve will be on manifold.

Ordering Code	Valve Model Number	NFPA Mounting Pad	Nominal Flow LPM(GPM)	Description	Circuit Symbol
B	D1VW001CN***	D03	26.5 (7)	Double (Spr. Ctr)	
C	D1VW004CN***	D03	26.5 (7)	Double (Spr. Ctr)	
F	D3W1CN**	D05	75.7 (20)	Double (Spr. Ctr)	
G	D3W4CN**	D05	56.8 (15)	Double (Spr. Ctr)	

† Units less valves will be supplied with station cover plates installed. Refer to options and accessories for voltage and connection choices.

Ordering Code	Function	Model Number	Technical Data
A*	Pump Case Heat Exchanger	RM-08-4-2	Air/Oil: 0.52 KW (0.7HP) Rejection @ 1.9 LPM (0.5 GPM) (1.5-11.2KW (2-15HP) Motors)
B1*	Return Heat Exchanger	RM-08-1-2	Air/Oil: 0.52 KW (0.7HP) Rejection @ 26.5 LPM (7 GPM) (1.5-3.7KW (2-5HP) Motors Only)
B2*	Return Heat Exchanger	RM-190-1-2	Air/Oil: 1.1KW (1.5HP) Rejection @ 26.5 LPM (7 GPM) (5.6-11.2KW (7.5-15HP) Motors Only)
H	Pressure Filter	15P110BXRS	Microglass II Element Vis. Ind. - 3.4 Bar (50 PSI) Bypass (0.28 Bar (4 PSI) Diff. @ 26.5 LPM (7 GPM))
K	Check Valve Pump Outlet	DT750MOMF05	0.34 Bar (5 PSI) Cracking Pressure (0.55 Bar (8 PSI) Diff. @ 26.5 LPM (7 GPM))
L	Bypass Check (On Heat Exch.)	C1220S65	4.48 Bar (65 PSI) Cracking Pressure
N	Return Filter	40CN110B	Microglass II Element Visual 1.72 Bar (25 PSI) Indicator (0.21 Bar (3 PSI) Diff. @ 26.5 LPM (7 GPM))
O	Return Filter	12AT10C [45.2 LPM (12 GPM) Max. Oil Flow]	Cellulose Element Ind. Gage - 1.03 Bar (15 PSI) Bypass
R1	Combination Float/Temp. SW N.O. Float Up	876782-01	Fixed Temp at 65°C (149°F) Close @ Low Level And/Or 65°C (149°F) (N.O.)
R2	Combination Float/Temp. SW N.O. Float Up	876782-02	Fixed Temp at 65.6°C (150°F) Open @ Low Level And/Or 65.6°C (150°F) (N.C.)

*Heat rejection based on flow given with a 4.4°C (40°F) differential between transfer medium.

Dimensions - Basic D-Pak (18.9 Liter (5 Gallon) Tank)

Inch equivalents for millimeter dimensions are shown in (**).

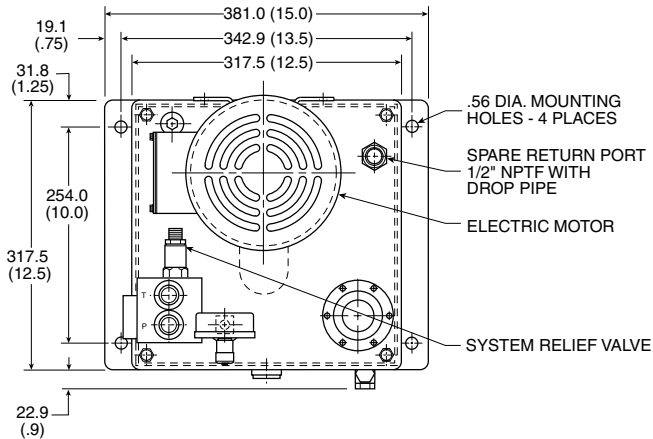

**“O” & “S3” OPTION MANIFOLD
 (P & T BLOCK & D03 SINGLE STATION)
 BASIC UNIT**

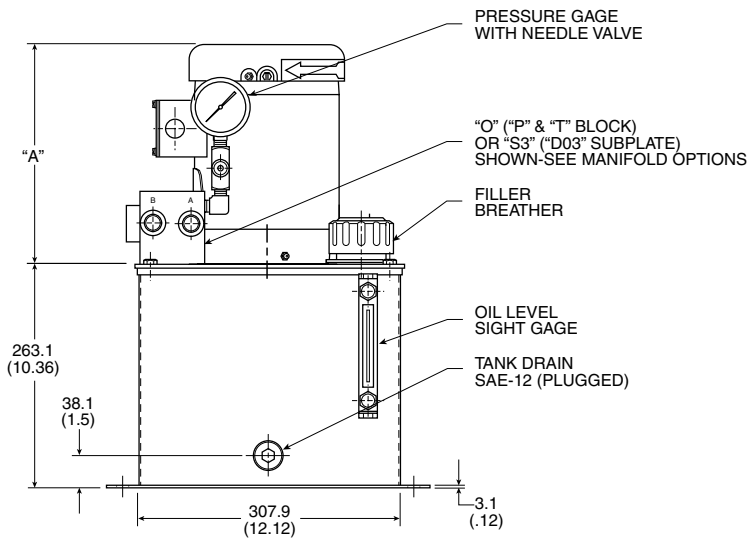

Motor Code	Motor Description KW(HP)-RPM-Frame-Phase	Dimension
		“A”
U1	.37 (.5)-1725-145TCZ-1	269.75 (10.62)
C1	.56 (.75)-1725-145TCZ-1	295.15 (11.62)
T1	.75 (1)-1725-145TCZ-1	295.15 (11.62)
T3	.75 (1)-1725-145TCZ-3	258.57 (10.18)
F	1.1 (1.5)-1725-145TCZ-3	283.97 (11.18)
G	1.5 (2)-1725-145TCZ-3	306.32 (12.06)
K	2.2 (3)-1725-145TCZ-3	341.37 (13.44)

Filter Option Reference

SPARE RETURN PORT
 1/2" NPTF
 WITH DROP PIPE

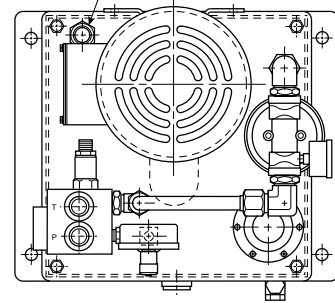

**“O” & “S3” OPTION MANIFOLD
 (P & T BLOCK & D03 SINGLE STATION)
 SHOWN WITH OPTION “O” RETURN FILTER**

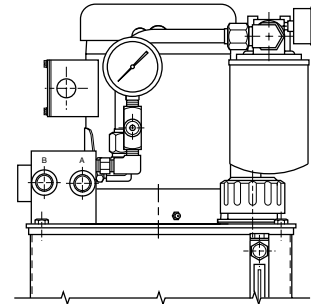

SPARE RETURN PORT
 1/2" NPTF
 WITH DROP PIPE

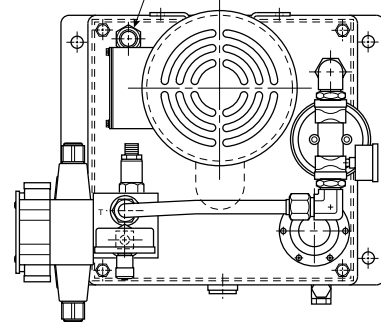

**“M3” & “C3” OPTION MANIFOLD
 (MULTI-STATION D03 MANIFOLD)
 SHOWN WITH OPTION “O” RETURN FILTER**

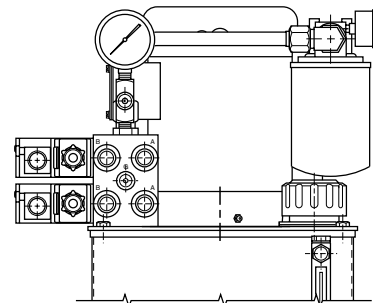

**Dimensions - Basic H1 & V1
 (10 Gallon Tank)**

Inch equivalents for millimeter dimensions are shown in (**).

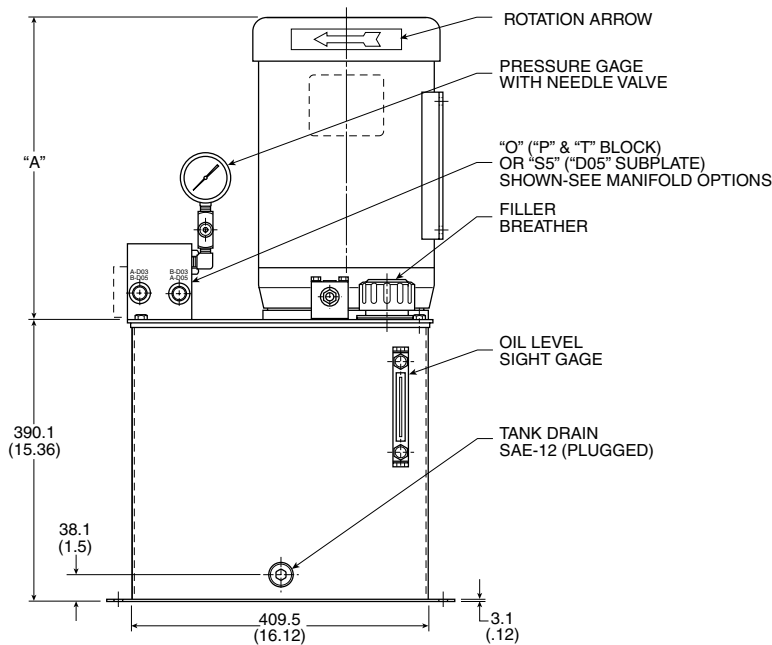
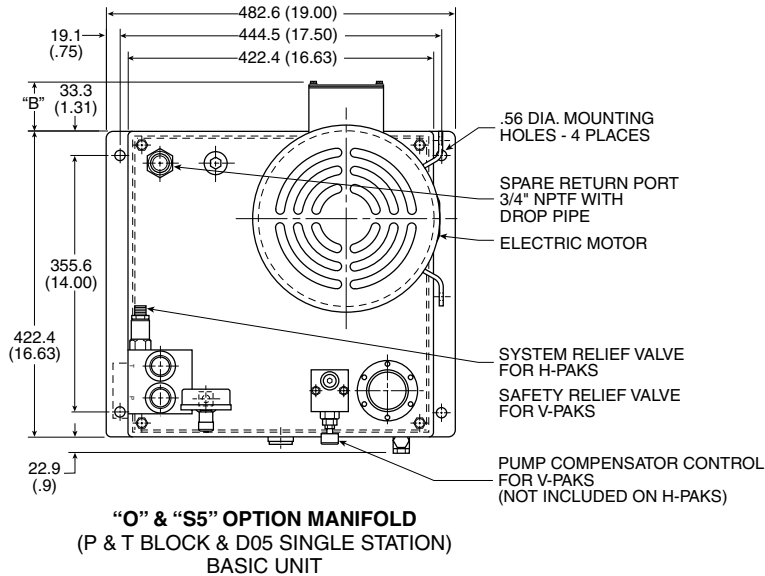

Motor Code	Motor Description KW(HP)-RPM-Frame-Phase	Dimension	
		"A"	"B"
U1	0.37 (.5)-1725-56C-1	266.70 (10.50)	19.05 (0.75)
C1	0.56 (.75)-1725-56C-1	279.40 (11.00)	19.05 (0.75)
T1	0.75 (1)-1725-56C-1	298.45 (11.75)	19.05 (0.75)
T3	0.75 (1)-1725-56C-3	266.70 (10.50)	19.05 (0.75)
F	1.1 (1.5)-1725-56C-3	273.05 (10.75)	19.05 (0.75)
G	1.5 (2)-1725-56C-3	298.45 (11.75)	19.05 (0.75)
K	2.2 (3)-1725-56C-3	320.55 (12.62)	19.05 (0.75)
L	3.7 (5)-1725-184TC-3	365.25 (14.38)	28.70 (1.13)
M	5.6 (7.5)-1725-213TC-3	406.40 (16.00)	66.80 (2.63)
N	7.5 (10)-1725-215TC-3	413.51 (16.28)	66.80 (2.63)

Filter Option Reference

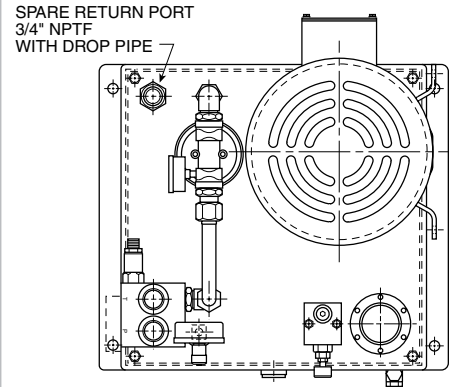

**"O" & "S5" OPTION MANIFOLD
 (P & T BLOCK & D05 SINGLE STATION)
 SHOWN WITH OPTION "O" RETURN FILTER**

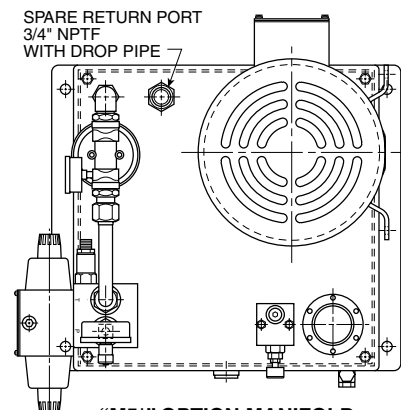
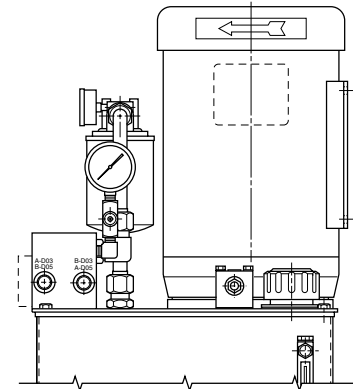

**"M5" OPTION MANIFOLD
 (MULTI-STATION D05 MANIFOLD)
 SHOWN WITH OPTION "O" RETURN FILTER**

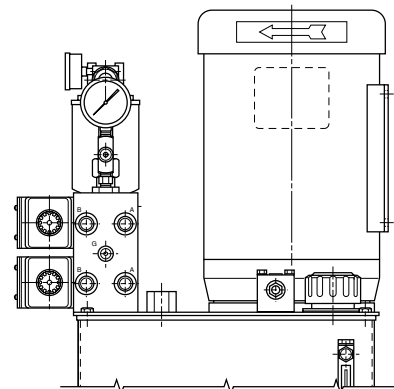

**Dimensions - Basic H2, 3, 4 & V2, 3, 4
 (20, 30, 40 Gallon Tank)**

Inch equivalents for millimeter dimensions are shown in (**).

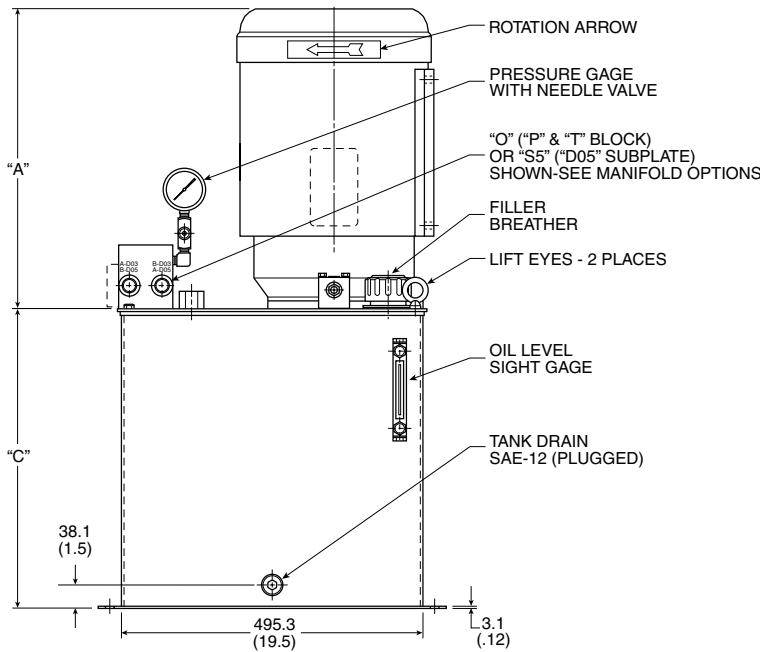
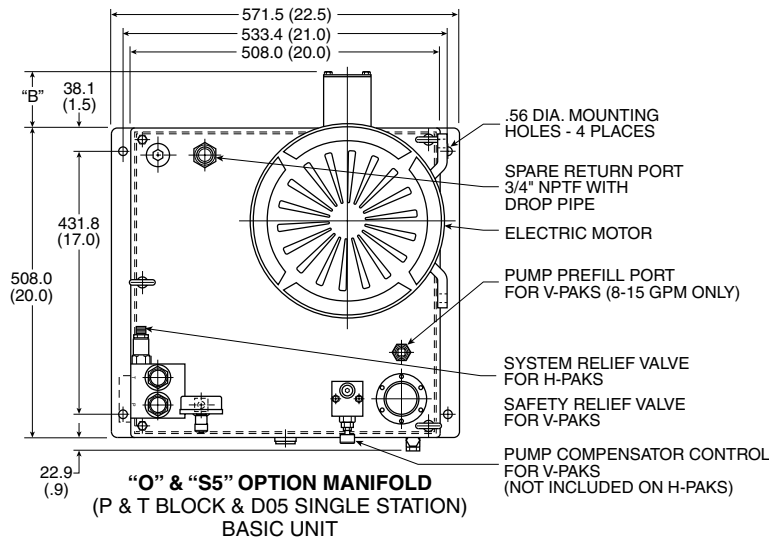

Motor Code	Motor Description KW(HP)-RPM-Frame-Phase	Dimension	
		"A"	"B"
U1	.37(.5) -1725-56C-1	266.70 (10.50)	19.05 (.75)
C1	.56(.75) -1725-56C-1	279.40 (11.00)	19.05 (.75)
T1	.75(1) -1725-56C-1	298.45 (11.75)	.75 (19.05)
T3	.75(1) -1725-56C-3	266.70 (10.50)	19.05 (.75)
F	1.1(1.5) -1725-56C-3	273.05 (10.75)	19.05 (.75)
G	1.5(2) -1725-56C-3	298.45 (11.75)	19.05 (.75)
K	2.2(3) -1725-56C-3	320.55 (12.62)	19.05 (.75)
L	3.7(5) -1725-184TC-3	365.25 (14.38)	28.70 (1.13)
M	5.6(7.5) -1725-213TC-3	406.40 (16.00)	35.05 (1.38)
N	7.5(10) -1725-215TC-3	413.51 (16.28)	35.05 (1.38)
P	11.2(15) -1725-254TC-3	447.80 (17.63)	85.09 (3.35)
S	14.9(20) -1725-256TC-3	492.25 (19.3)	85.09 (3.35)

Reservoir Code	Reservoir Size	Dimension "C"
H2 or V2	151.4 Liters (20 Gal)	491.74 (19.36)
H3 or V3	113.6 Liters (30 Gal)	599.95 (23.62)
H4 or V4	75.7 Liters (40 Gal)	733.04 (28.86)

Filter Option Reference

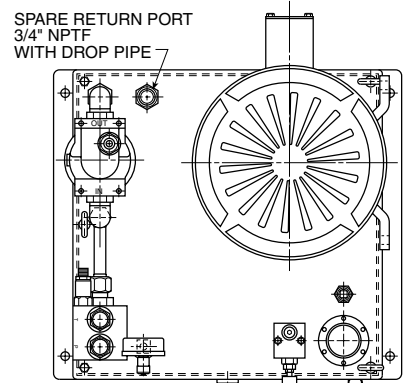

**"O" & "S5" OPTION MANIFOLD
 (P & T BLOCK & D05 SINGLE STATION)
 SHOWN WITH OPTION "N" RETURN FILTER**

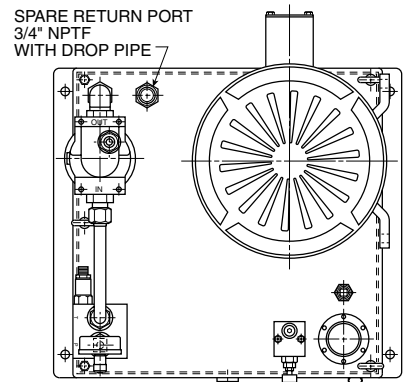
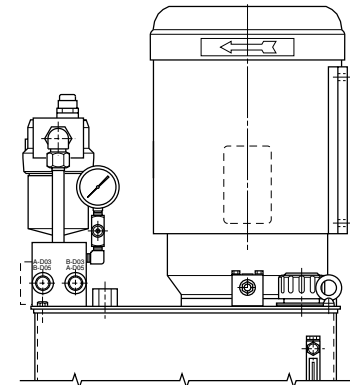

**"M5" OPTION MANIFOLD
 (MULTI-STATION D05 MANIFOLD)
 SHOWN WITH OPTION "N" RETURN FILTER**

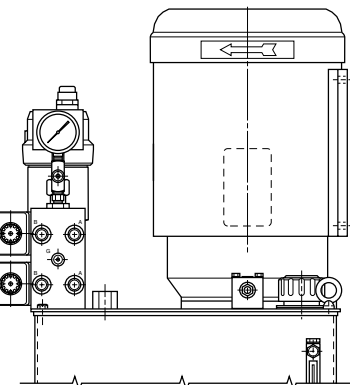

Manifold Options

Inch equivalents for millimeter dimensions are shown in (**).

<p style="text-align: center;">O</p> <p style="text-align: center;">MANIFOLD OPTION FOR SUPPLY & RETURN CONNECTIONS (18.9 LITER (5 GAL.) RESERVOIR UNITS)</p>	<p style="text-align: center;">S3</p> <p style="text-align: center;">SUBPLATE OPTION FOR USE WITH D1VW VALVE (NFPA D03)</p>
<p style="text-align: center;">O</p> <p style="text-align: center;">MANIFOLD OPTION FOR SUPPLY & RETURN CONNECTIONS (37.9, 75.7, 113.6, 115.4 LIT (10, 20, 30, 40 GAL) RESERVOIR UNITS)</p>	<p style="text-align: center;">S5</p> <p style="text-align: center;">SUBPLATE OPTION FOR USE WITH D3W VALVE (NFPA D05)</p>

Manifold Options

Inch equivalents for millimeter dimensions are shown in (**).

Option M33/M35

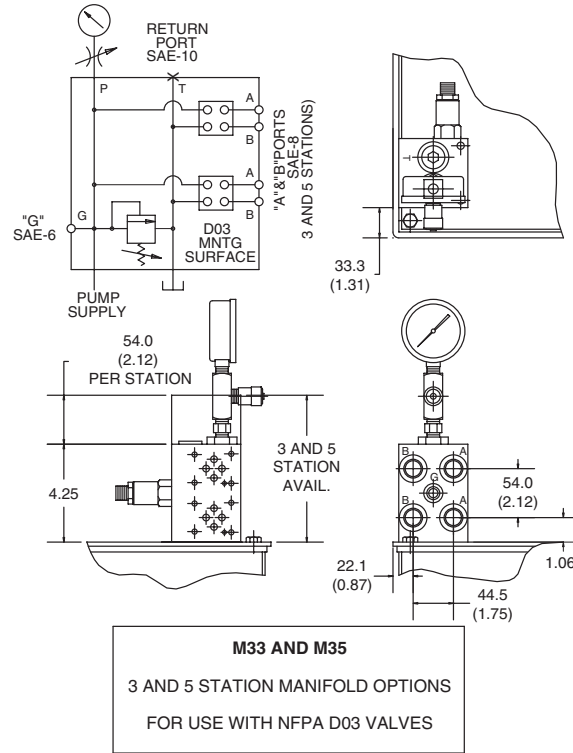

Option M53/M55

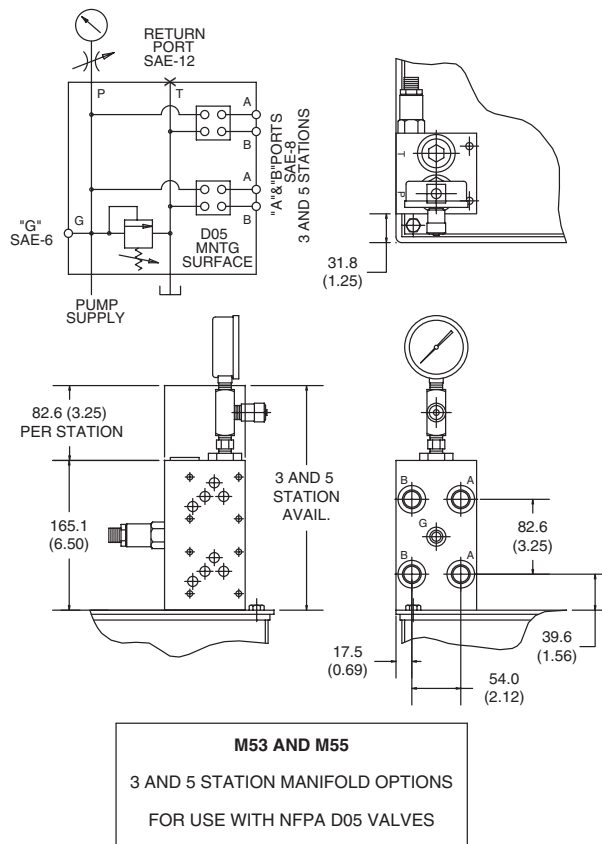

Pressure Control Option "B" - Unloading Valve

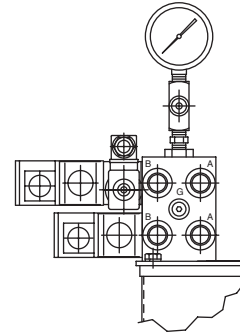
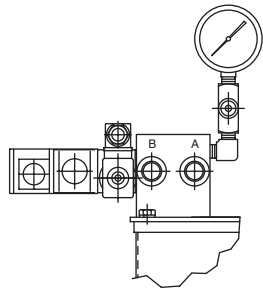
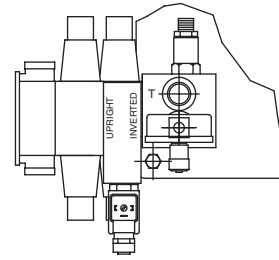
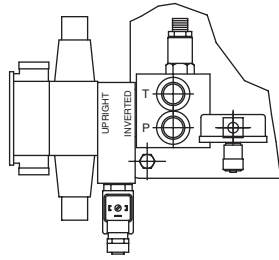

"H"PAK WITH
 "S3" MANIFOLD
 3.4-19.3 LPM (0.9-5.1 GPM) FLOW RATES ONLY
 (CONNECTED TO SYSTEM RETURN LINE)

"H"PAK WITH
 "M3*" MANIFOLD
 3.4-19.3 LPM (0.9-5.1 GPM) FLOW RATES ONLY
 (CONNECTED TO SYSTEM RETURN LINE)

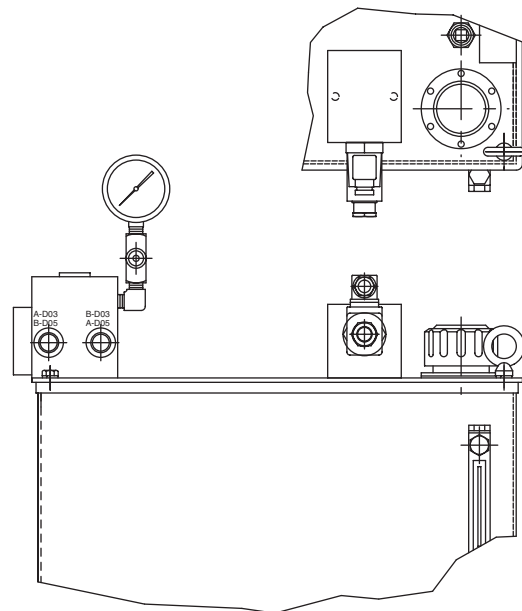
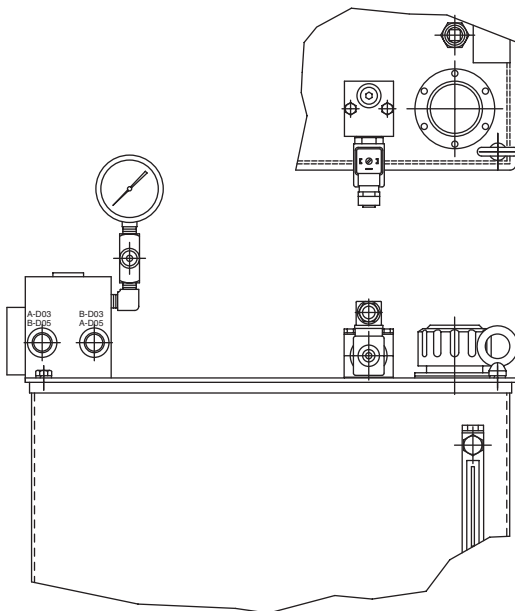

"H"PAK WITH
 "OMIT", "S5", "S6", "M5*", "M6*" MANIFOLDS
 3.4-19.3 LPM (0.9-5.1 GPM) FLOW RATES ONLY
 (PLUMBED DIRECTLY BACK TO TANK)

"H"PAK WITH
 "OMIT", "S3", "S5", "S6", "M3*", "M5*", "M6*" MANIFOLDS
 23.84-46.56 LPM (6.3-12.3 GPM) FLOW RATES ONLY
 (PLUMBED DIRECTLY BACK TO TANK)

Pressure Control Option "B" - Unloading Valve

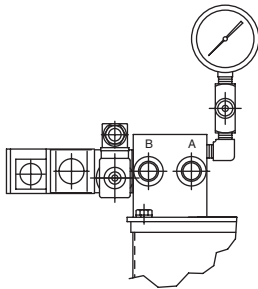
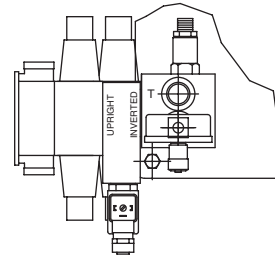
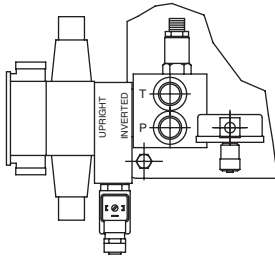

"D"PAK WITH
"S3" MANIFOLD
(CONNECTED TO SYSTEM RETURN)

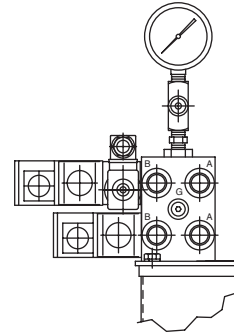

"D"PAK WITH
"M3" MANIFOLD
(CONNECTED TO SYSTEM RETURN)

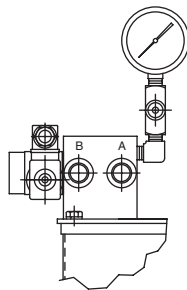
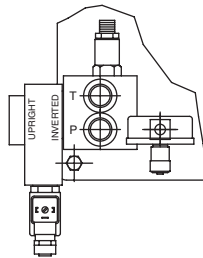

"D"PAK WITH
"OMIT" MANIFOLD
(CONNECTED TO SYSTEM RETURN)

V-Pak – Compensator Options

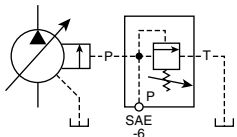
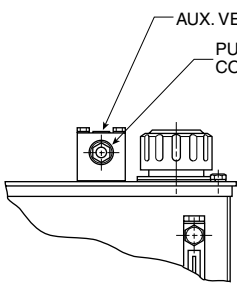
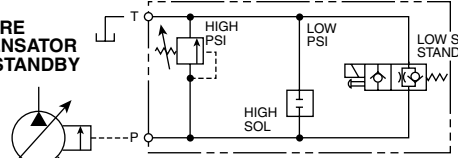
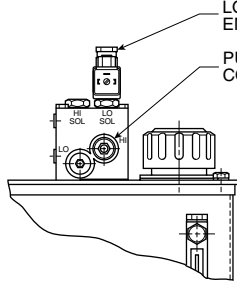
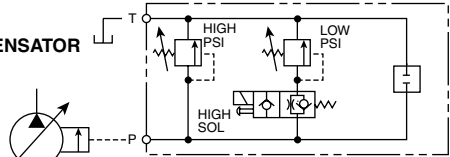
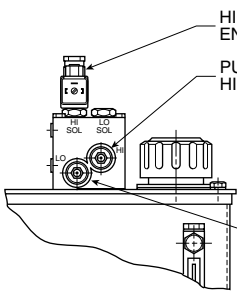
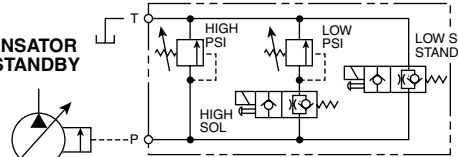
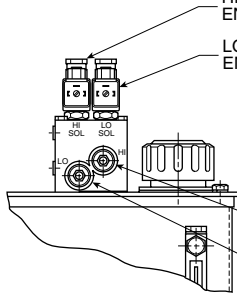
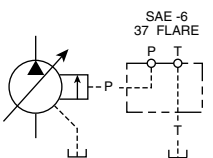
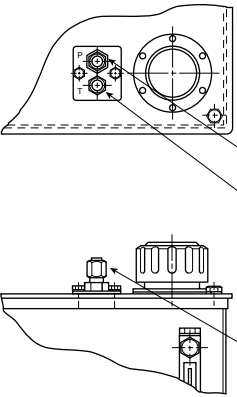
<p>“OMIT” OPTION SINGLE PRESSURE REMOTE COMPENSATOR</p>   <p>AUX. VENT PORT (SAE-6) PUMP COMPENSATOR CONTROL ADJUSTMENT</p>	<p>“B” OPTION SINGLE PRESSURE REMOTE COMPENSATOR W/LOW PRESS. STANDBY</p>   <p>SOLENOID IS LOW WATT WITH DIN. 43650 CONNECTOR AND MANUAL OVERRIDE</p> <p>LOW PRESS. STANDBY (N.O.) ENERGIZE TO BUILD PRESSURE PUMP COMPENSATOR CONTROL ADJUSTMENT</p>
<p>“C” OPTION BI-PRESSURE REMOTE COMPENSATOR</p>   <p>SOLENOID IS LOW WATT WITH DIN. 43650 CONNECTOR AND MANUAL OVERRIDE</p> <p>HIGH PRESS. SOLENOID (N.O.) ENERGIZE FOR HIGH PRESSURE PUMP COMPENSATOR HIGH PRESS. CONTROL PUMP COMPENSATOR LOW PRESS. CONTROL</p>	<p>“D” OPTION BI-PRESSURE REMOTE COMPENSATOR W/LOW PRESS. STANDBY</p>   <p>SOLENOID IS LOW WATT WITH DIN. 43650 CONNECTOR AND MANUAL OVERRIDE</p> <p>HIGH PRESS. SOLENOID (N.O.) ENERGIZE FOR HIGH PRESSURE LOW PRESS. STANDBY (N.O.) ENERGIZE FOR LOW PRESSURE PUMP COMPENSATOR HIGH PRESSURE CONTROL PUMP COMPENSATOR LOW PRESSURE CONTROL</p>
<p>“F” OPTION PROVISION FOR CUSTOMER SUPPLIED REMOTE COMPENSATOR</p>   <p>SAE-6 37 FLARE</p> <p>PUMP COMPENSATOR PRESSURE (INLET) PORT PUMP COMPENSATOR TANK (RETURN) PORT SAE-6 37 FLARE “P” & “T” PORTS ATTACH POINTS FOR CUSTOMER SUPPLIED REMOTE COMPENSATOR</p>	

Accessory Options

D & H-PAKS

- | | | | |
|----------|---|----------|--|
| Option B | Return Line Air/Oil Heat Exchanger (B1 or B2) | Option N | Return Line Filter |
| Option H | Pressure Filter | Option O | Return Line Filter |
| Option K | Check Valve – Pump Outlet | Option R | Combination Temp/Level Switch (R1 or R2) |
| Option L | Check Valve – Return Line Bypass | | |

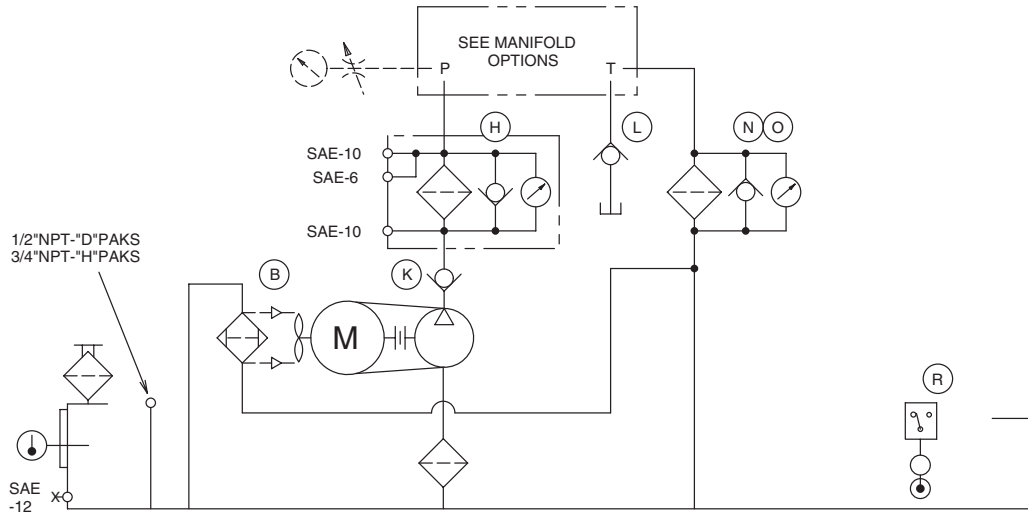

V-PAKS

- | | | | |
|----------|---|----------|--|
| Option A | Pump Case Heat Exchanger | Option L | Check Valve – Return Line Bypass |
| Option B | Return Line Air/Oil Heat Exchanger (B1 or B2) | Option N | Return Line Filter |
| Option H | Pressure Filter | Option O | Return Line Filter |
| Option K | Check Valve – Pump Outlet | Option R | Combination Temp/Level Switch (R1 or R2) |

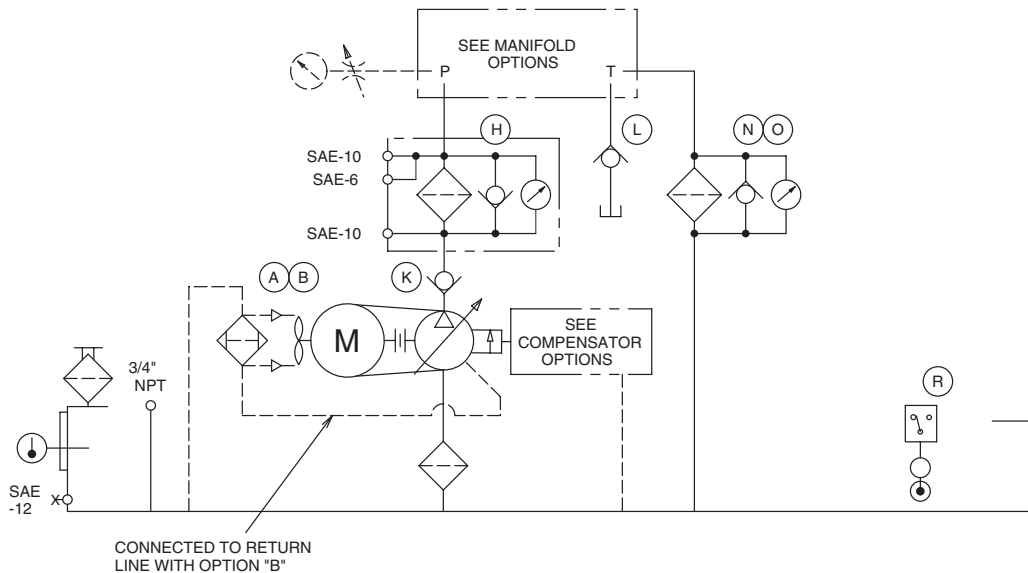

Dimensions - D-Pak (5 Gallon Tank) Accessories

Inch equivalents for millimeter dimensions are shown in (**).

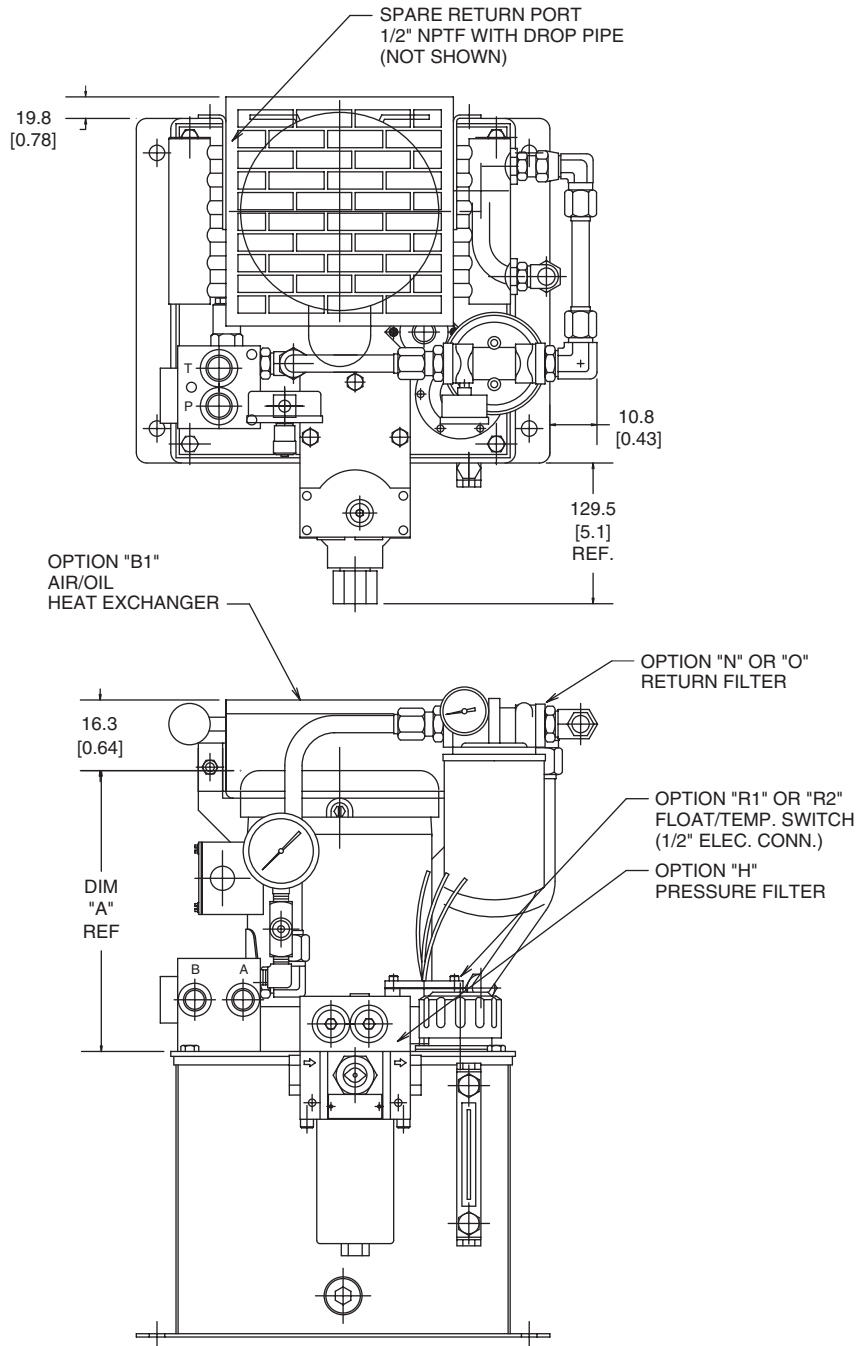

Dimensions - H1 & V1 (10 Gallon Tank) Accessories

Inch equivalents for millimeter dimensions are shown in (**).

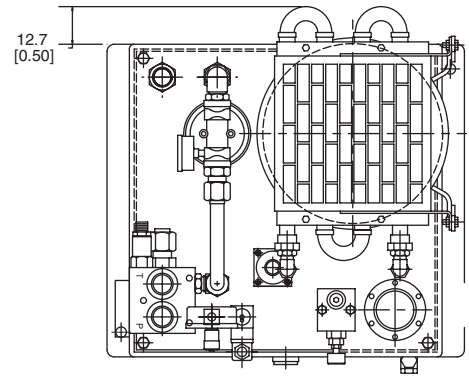
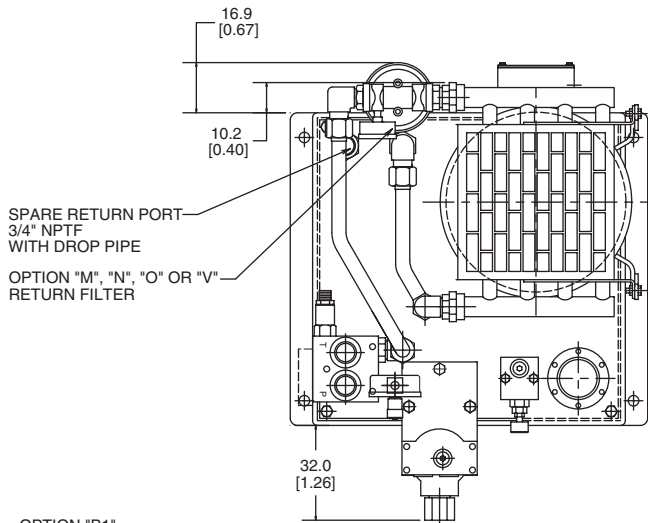

OPTION "B1"
 AIR/OIL
 HEAT EXCHANGER

OPTION "A"
 PUMP CASE HEAT EXCHANGER
 (USED ON "V" PAKS ONLY)

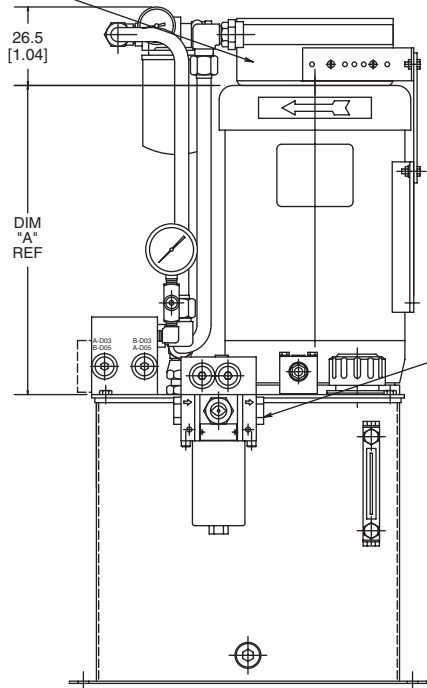

OPTION "R1" OR "R2"
 FLOAT/TEMP. SWITCH
 (1/2" ELEC. CONN.)

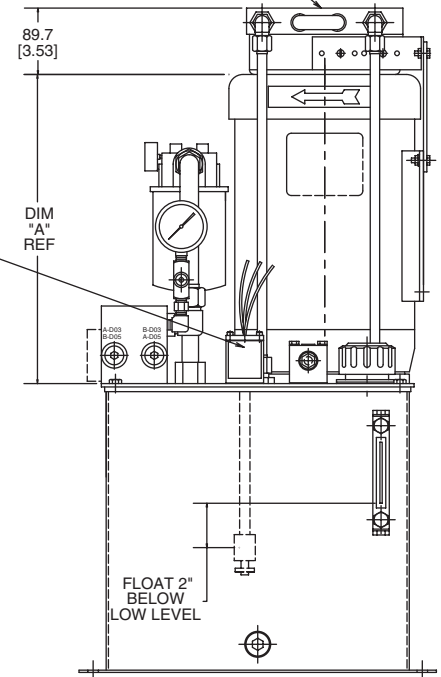

Dimensions - H2, 3, 4 & V2, 3, 4 (20, 30, 40 Gallon Tank) Accessories

Inch equivalents for millimeter dimensions are shown in (**).

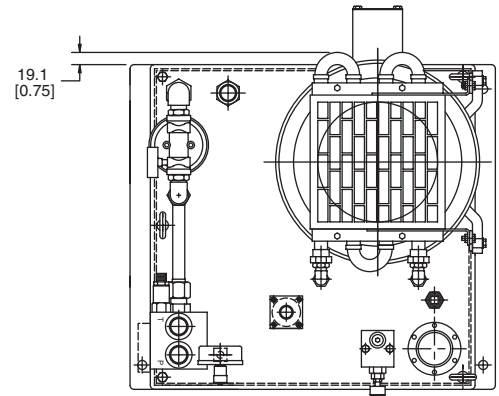
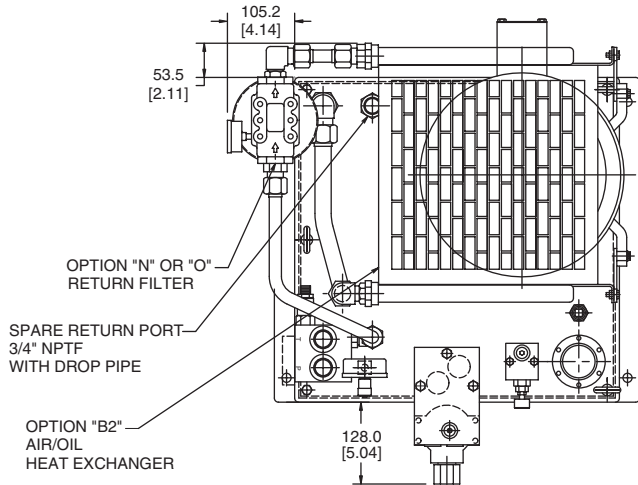

OPTION "A" PUMP CASE HEAT EXCHANGER (USED ON V-PAKS ONLY)

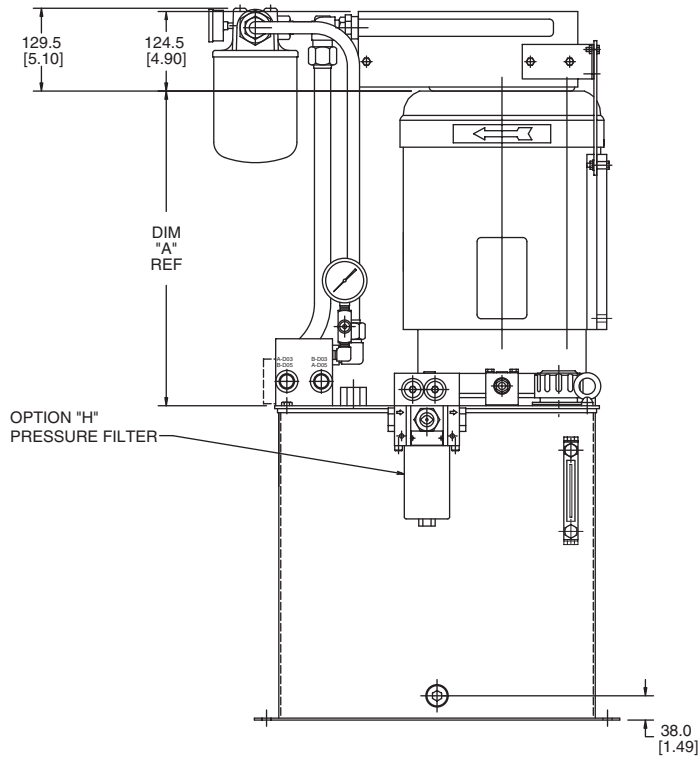

OPTION "R1" OR "R2" FLOAT/TEMP. SWITCH (1/2"ELEC. CONN.)

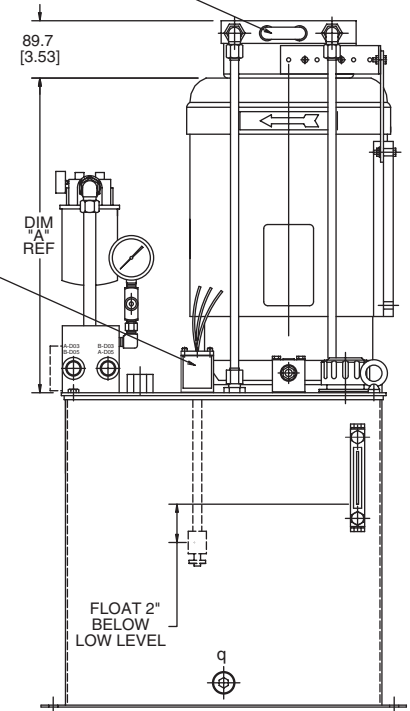

Performance Data – Maximum Working Pressures

**** Represents maximum operating pressure with pump/motor combination. This will be the maximum relief valve or compensator setting.

***** Represents maximum operating pressure with pump/motor combination. When used on power unit products this will represent a 206.8 Bar (3000 PSI) relief valve or compensator setting.

D & H-Pak - Pump/Motor Combinations Maximum Operating Pressure Bar (PSI)

Pump Code Flow at 1725 RPM LPM (GPM)	Motor KW (HP)										
	.37 (.5)	.60 (.75)	.75 (1)	1.1 (1.5)	1.5 (2)	2.2 (3)	3.7 (5)	5.6 (7.5)	7.5 (10)	11.2 (15)	14.9 (20)
	Max Operating Pressure (Theoretical)										
3.4 (0.9)	55.8(810)	84.1(1220)	111.7(1620)	167.5(2430)	223.4(3240)						
4.9 (1.3)	40.0(580)	60.0(870)	80.0(1160)	119.3(1730)	159.3(2310)	239.2(3470)					
6.8 (1.8)	29.6(430)	44.1(640)	59.3(860)	88.3(1280)	118.6(1720)	177.2(2570)	275.0(3988)				
8.7 (2.3)	22.8(330)	34.5(500)	46.2(670)	69.0(1000)	92.4(1340)	138.6(2010)	231.0(3350)				
10.2 (2.7)	20.0(290)	30.3(440)	40.0(580)	60.0(870)	80.7(1170)	120.7(1750)	201.3(2920)	275.0(3988)			
12.1 (3.2)	15.9(230)	24.1(350)	31.7(460)	48.3(700)	64.1(930)	96.5(1400)	160.6(2330)	241.3(3500)			
17.0 (4.5)	11.0(160)	17.2(250)	22.8(330)	33.8(490)	45.5(660)	69.0(1000)	115.1(1670)	172.4(2500)	228.9(3320)		
19.3 (5.1)	10.3(150)	15.2(220)	20.7(300)	30.3(440)	40.7(590)	61.4(890)	102.0(1480)	153.1(2220)	204.1(2960)	275.0(3988)	
23.8 (6.3)	8.3(120)	12.4(180)	16.5(240)	24.8(360)	33.1(480)	49.6(720)	82.7(1200)	124.1(1800)	165.5(2400)	248.2(3600)	
30.7 (8.1)		9.7(140)	12.4(180)	18.6(270)	24.8(360)	37.2(540)	62.7(910)	93.8(1360)	125.5(1820)	187.5(2720)	251.0(3640)
35.6 (9.4)		8.3(120)	11.0(160)	16.5(240)	21.4(310)	32.4(470)	53.8(780)	81.4(1180)	108.2(1570)	162.0(2350)	215.8(3130)
46.6 (12.3)			8.3(120)	11.7(170)	15.9(230)	24.1(350)	40.0(580)	60.0(870)	80.0(1160)	120.0(1740)	160.0(2320)

V-Pak - Pump/Motor Combinations Maximum Operating Pressure Bar (PSI)

Pump	LPM (GPM) @ 1725 RPM	Motor KW (HP)						
		1.5 (2)	2.2 (3)	3.7 (5)	5.6 (7.5)	7.5 (10)	11.2 (15)	14.9 (20)
PVP16	7.6 (2.0)	72.4(1050)	108.2(1570)	179.3(2600)	266.1(3860)			
PVP16	9.5 (2.5)	64.1(930)	94.5(1370)	155.1(2250)	232.4(3370)			
PVP16	11.4 (3.0)	57.2(830)	84.8(1230)	137.9(2000)	206.8(3000)			
PVP16	13.2 (3.5)	51.7(750)	75.8(1100)	124.1(1800)	184.8(2680)	246.1(3570)		
PVP16	15.1 (4.0)	46.9(680)	68.9(1000)	113.8(1650)	168.2(2440)	223.4(3240)		
PVP16	17.0 (4.5)	43.4(630)	63.4(920)	103.4(1500)	153.8(2230)	204.8(2970)	305.4(4430)	
PVP16	18.9 (5.0)	40.0(580)	58.6(850)	96.5(1400)	142.0(2060)	188.9(2740)	281.3(4080)	
PVP16	20.8 (5.5)	37.9(550)	55.2(800)	89.6(1300)	132.4(1920)	175.1(2540)	261.3(3790)	
PVP16	22.7 (6.0)	35.2(510)	51.7(750)	83.4(1210)	123.4(1790)	163.4(2370)	244.1(3540)	
PVP16	24.6 (6.5)	33.1(480)	48.3(700)	77.9(1130)	115.8(1680)	153.0(2220)	228.2(3310)	
PVP16	26.5 (7.0)	31.0(450)	45.5(660)	73.8(1070)	108.9(1580)	144.8(2100)	215.1(3120)	
PVP33	30.3 (8.0)		41.4(600)	66.2(960)	97.9(1420)	129.6(1880)	193.1(2800)	255.1(3700)
PVP33	32.2 (8.5)		39.3(570)	64.1(930)	93.1(1350)	123.4(1790)	182.7(2650)	242.7(3520)
PVP33	34.1 (9.0)		37.2(540)	60.7(880)	88.9(1290)	117.2(1700)	174.4(2530)	231.0(3350)
PVP33	36.0 (9.5)		35.9(520)	57.9(840)	84.8(1230)	112.4(1630)	166.2(2410)	220.6(3200)
PVP33	37.9 (10.0)		34.5(500)	55.2(800)	81.4(1180)	106.9(1550)	159.3(2310)	206.8(3000)
PVP33	39.7 (10.5)		33.1(480)	53.1(770)	77.9(1130)	102.7(1490)	152.4(2210)	202.7(2940)
PVP33	41.6 (11.0)		31.7(460)	51.0(740)	75.2(1090)	98.6(1430)	146.9(2130)	194.4(2820)
PVP33	43.5 (11.5)		31.0(450)	49.0(710)	72.4(1050)	95.1(1380)	141.3(2050)	186.8(2710)
PVP33	45.4 (12.0)		29.6(430)	47.6(690)	69.6(1010)	91.7(1330)	135.8(1970)	180.0(2610)
PVP33	47.3 (12.5)		29.0(420)	46.2(670)	66.9(970)	88.3(1280)	131.0(1900)	173.7(2520)
PVP33	49.2 (13.0)		28.3(410)	44.8(650)	64.8(940)	85.5(1240)	126.9(1840)	167.5(2430)
PVP33	51.1 (13.5)		26.9(390)	43.4(630)	62.7(910)	82.7(1200)	122.7(1780)	162.0(2350)
PVP33	53.0 (14.0)		26.2(380)	42.1(610)	60.7(880)	80.0(1160)	118.6(1720)	157.2(2280)
PVP33	54.9 (14.5)		25.5(370)	40.7(590)	59.3(860)	77.9(1130)	115.1(1670)	152.4(2210)
PVP33	56.8 (15.0)		24.8(360)	39.3(570)	57.2(830)	75.2(1090)	111.7(1620)	147.5(2140)

Performance Data – Pumps

Standard Pumps

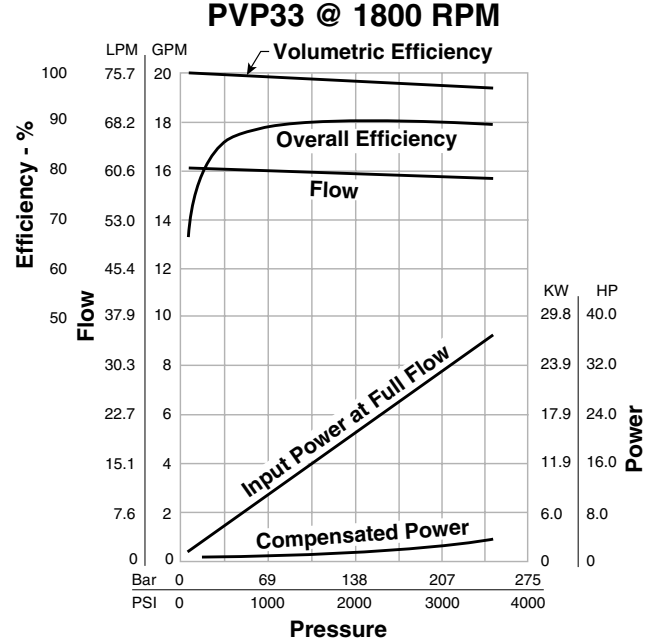
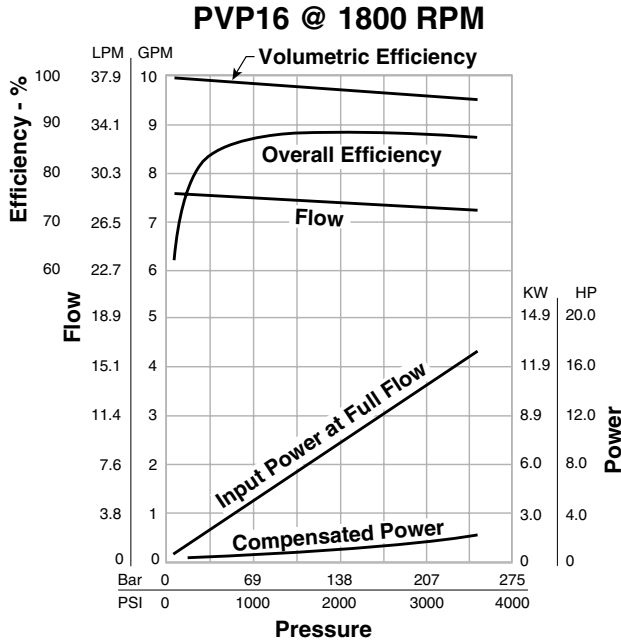

NOTE: The efficiencies and data in the graph are good only for pumps running at 1800 RPM and stroked to maximum. To calculate approximate horsepower for the other conditions, use the following formula:

$$HP = \left[\frac{Q \times (PSI)}{1714} \right] + (CHp) \times \frac{N}{1800}$$

Actual GPM is directly proportional to drive speed and maximum volume setting. Flow loss, however, is a function of pressure only.

WHERE:

Q = Actual Output Flow in GPM

PSI = Pressure At Pump Outlet

CHp = Input Horsepower @ Full compensation @ 1800 RPM (from graph read at operating pressure)

N = Drive Speed in RPM

Horsepower Limited Pumps

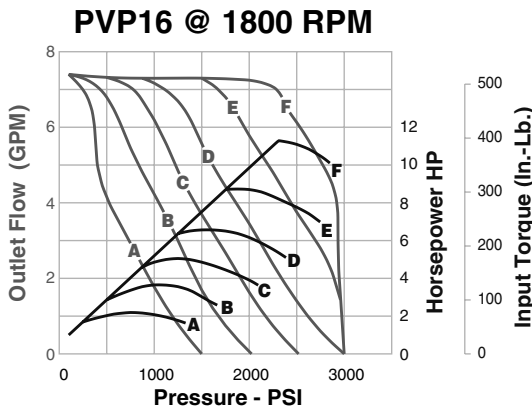

	MOTOR KW (HP)					
	1.5(2)	2.2(3)	3.7(5)	5.6(7.5)	7.5(10)	11.2(15)
	Compensator Setting Bar (PSI)					
PVP16	110.3	151.7	206.8	206.8	206.8	206.8
FULL STROKE	(1600)	(2200)	(3000)	(3000)	(3000)	(3000)

Pump Control Option "H" with PVP16
Horsepower Limiting
Factory Compensator Settings

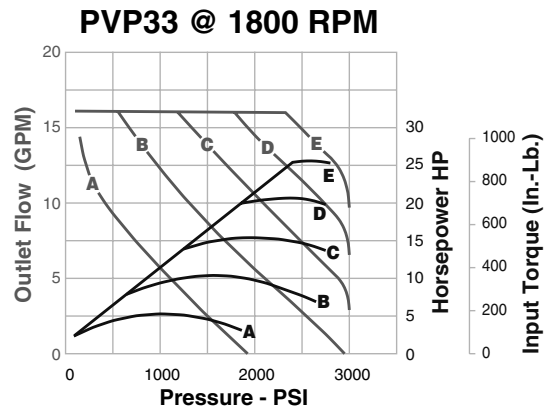

	MOTOR KW (HP)			
	5.6(7.5)	7.5(10)	11.2(15)	14.9(20)
	Compensator Setting Bar (PSI)			
PVP33	151.7	186.2	206.8	206.8
FULL STROKE	(2200)	(2700)	(3000)	(3000)

Pump Control Option "H" with PVP33
Horsepower Limiting
Factory Compensator Settings

Performance Data – Heat Exchangers

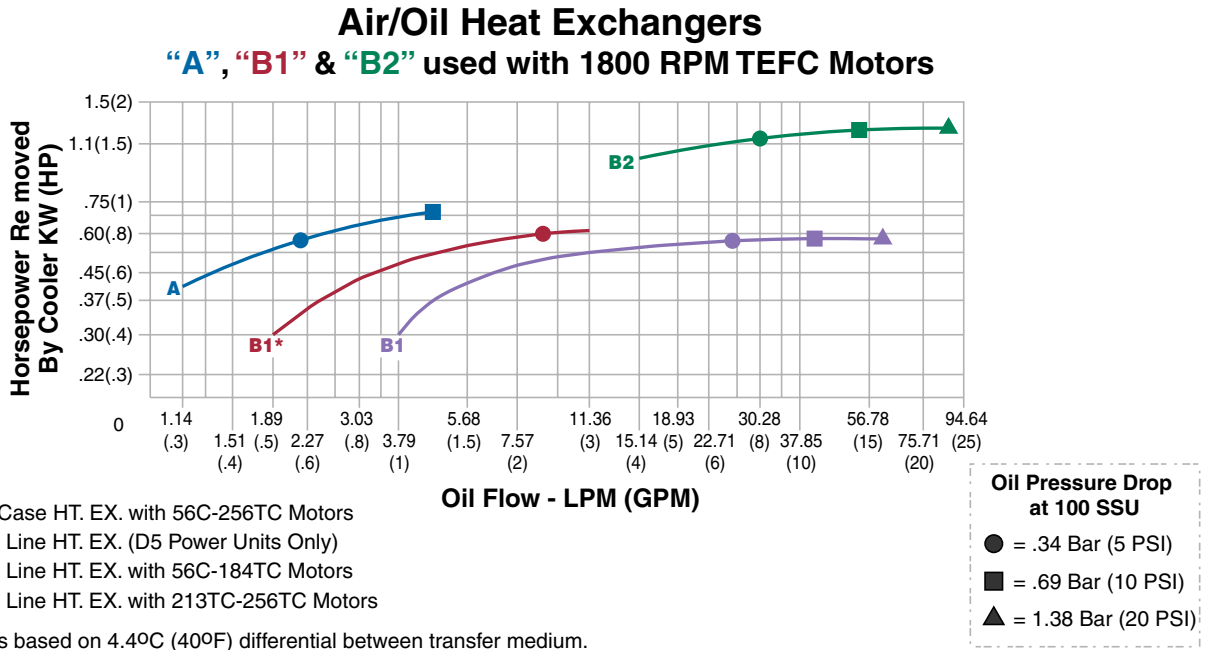

Horsepower Removed By Reservoir

KW (HP) REMOVAL	RESERVOIR SIZE LITERS (GALLONS)				
	18.9(5)	37.9(10)	75.7(20)	113.6(30)	151.4(40)
	.15(.2)	.28(.38)	.43(.58)	.51(.68)	.60(.81)

Heat removal is based on static ambient air at 29.4°C (85°F) and max. oil temperature of 57.2°C (135°F).



Operating Notes

- Jog the electric motor once and verify that the electric motor is rotating in the same direction as the arrow on the electric motor housing. If direction is incorrect, reverse two of the three leads on a 3-phase electric motor.
- D & H-Pak power units are tested and relief valve is set at maximum pressure of the pump/motor combination.
- V-Pak power units are tested and pressure control valves are factory preset. If adjustments are needed, follow the procedure below: Begin adjusting relief valve and pump compensator control valve to increase pressure gradually. (**NOTE:** Always set relief valve 250 PSI higher than pump compensator pressure control valve or severe overheating will occur.)
- If pump fails to prime, vent pump discharge to atmosphere to establish fluid flow.
- Reservoir temperature should not exceed 150°F. System reliability and component service life will be reduced when system is operated at higher temperature.
- Clean fluid = improved system reliability and longer component service life, change filter elements whenever filter indicators indicate a dirty element condition.

- It is recommended that every 4,000 operating hours or once a year, whichever occurs first, the filler/breather cap and suction strainer should be replaced.

Fluid Recommendations

Premium quality hydraulic oil with a viscosity range between 150-250 SSU (30-50 cst.) at 100°F (38°C). Normal operating viscosity range between 80-1000 SSU (17-180 cst.). Maximum start-up viscosity is 4000 SSU (1000 cst.).

NOTE: Consult Parker when exceeding 160°F (71°C) operation. Oil should have maximum anti-wear properties, rust and oxidation treatment.

Filtration

For maximum pump and system component life, the system should be protected from contamination at a level not to exceed 125 particles greater than 10 microns per milliliter of fluid. (SAE Class 4 / ISO 16/13.) Due to the nature of variable displacement pumps, variations in pump inlet conditions, fluid acceleration losses, system aeration, and duty cycle must be carefully considered before specifying suction line filtration. Contact your Parker representative for assistance.

NOTE: For additional information refer to latest edition of Bulletin No. HY13-2600-550-xxx..

The totally enclosed pump mounting bracket offers precision shaft alignment and safety from the rotating shafts and coupling. The bracket is designed to mount on the motor face with the motor coupling half secure to the shaft. Then the pump, with its coupling half secure on the pump shaft, is mounted and the coupling halves are engaged. This will require proper spacing of the coupling prior to installation and a coupling with an outside diameter less than "P" dimension. If the coupling selected cannot be assembled this way, both coupling halves must be installed on the motor shaft. Next, mount the adapter on the motor. Then the pump can be mounted and the coupling secured to the pump by using the access slot to tighten the pump shaft coupling set screw.

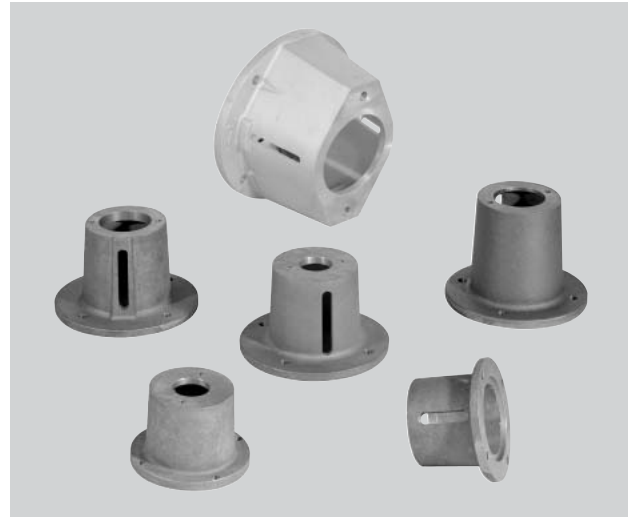

Dimensions*
 Pump Mounting Adapter

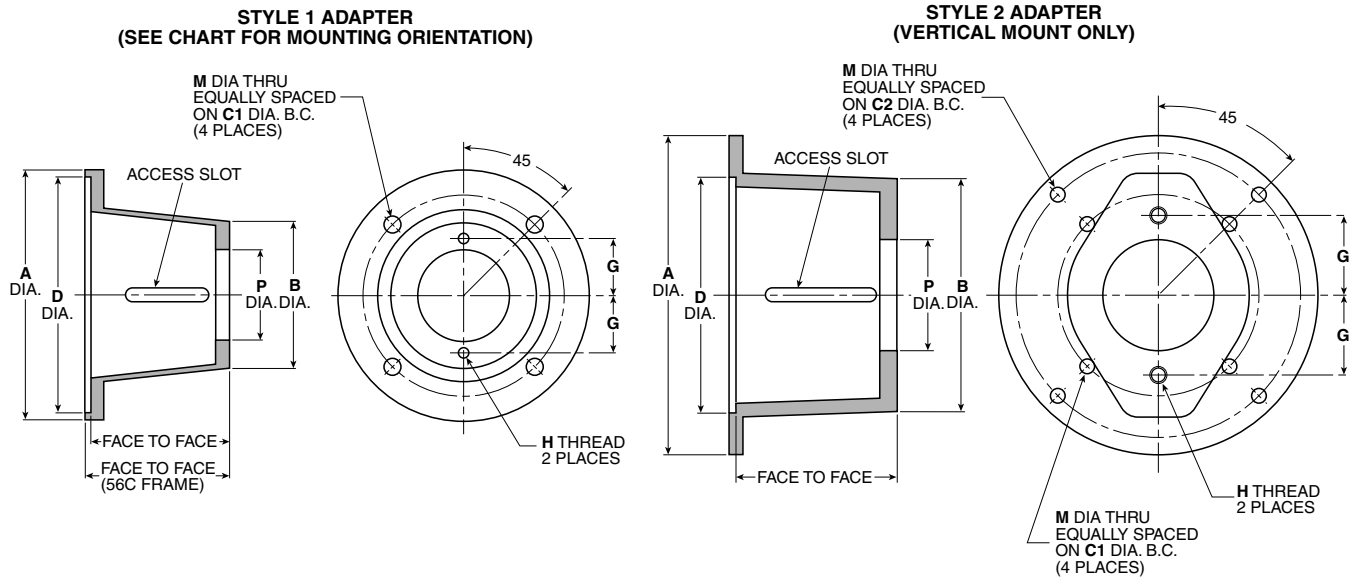

Model Number	Pump Mounting	Motor Mounting	A	B	C1	C2	D	Face to Face	G	H	M	P	Vertical Mounting	Horizontal Mounting	Style	Weight
876631	SAE AA	56C	6.7	5.0	5.88	N/A	4.50	3.50	1.63	3/8-16	0.44	2.00	YES	YES	1	3 lb.
876632	SAE AA	182TC/256TC	9.0	5.3	7.25	N/A	8.50	5.00	1.63	3/8-16	0.56	2.00	YES	YES	1	4 lb.
876633	SAE A	56C	6.7	5.0	5.88	N/A	4.50	4.25	2.10	3/8-16	0.44	3.25	YES	YES	1	4 lb.
876634	SAE A	182TC/256TC	9.0	5.3	7.25	N/A	8.50	5.00	2.10	3/8-16	0.56	3.25	YES	YES	1	4 lb.
876635	SAE A	182TC/256TC	9.0	5.3	7.25	N/A	8.50	5.88	2.10	3/8-16	0.56	3.25	YES	YES	1	5 lb.
875343	SAE B	182TC/256TC	11.4	9.0	7.25	10.25	8.50	5.75	2.88	1/2-13	0.53	4.00	YES	NO	2	7 lb.
875344	SAE B	182TC/256TC	11.4	9.0	7.25	10.25	8.50	6.81	2.88	1/2-13	0.53	4.00	YES	NO	2	8 lb.
876683	SAE B	182TC/256TC	9.0	8.8	7.25	N/A	8.50	6.38	2.88	1/2-13	0.53	4.00	NO	YES	1	7 lb.
876684	SAE C	182TC/256TC	9.0	9.3	7.25	N/A	8.50	6.69	3.56	5/8-11	0.53	5.00	NO	YES	1	20 lb.

* All dimensions are in inches.

NOTE: It is the responsibility of the user to check the listed dimensions to ensure suitability of mounting adapter with pump/coupling/motor combination.

Application Formulas

- 1 GPM at 1500 PSI = 1 HP (General Rule)
- 1 Gallon = 231 Cubic Inches (3.7854 Liters)
- 1 Gallon Oil = 7.08 Lbs.
- 1 bar = 14.5 PSI
- 25.4mm = 1 Inch
- 1 HP = 42.4 BTU/Min.
- 1 Gallon = 3.7854 Liters

$$\text{HP} = \frac{\text{GPM} \times \text{PSI}}{1714 \times \text{Pump Efficiency}}$$

$$\text{PSI} = \frac{1714 \times \text{Pump Efficiency} \times \text{HP}}{\text{GPM}}$$

$$\text{GPM} = \frac{1714 \times \text{Pump Efficiency} \times \text{HP}}{\text{PSI}}$$

$$\text{HP} = \frac{\text{Torque (in.-lbs.)} \times \text{RPM}}{63025}$$

$$\text{Torque} = \frac{\text{HP} \times 63025}{\text{RPM}}$$

$$\text{RPM} = \frac{\text{HP} \times 63025}{\text{Torque}}$$

Motor Information

- At 440V — 3-Phase Motor Draws 1.25 AMP/HP
 At 220V — 3-Phase Motor Draws 2.5 AMP/HP
 At 110V — Single Phase Motor Draws 10 AMP/HP